

Sensor Distribution Box (M12 4-Pin/5-Pin Connector Type)

■ Features

- Easy check operation by operation indicator (red)
- Single power operates several sensors
- Convenient wiring and power line
- IP67 protection structure with water-proof cover (IP66 protection structure with protection cover)
- Supports 1-signal, 2-signal (DC 4-wire)

⚠ Please read "Caution for your safety" in operation manual before using.

M12 4-pin connector type



Cable type



M12 5-pin connector type

Line-up



■ Ordering Information

PT	4		3D	N	5	5	
							Cable length*2
							Number of M12 connector pins
							Input logic*1
							Output type
							Connection method for external signal
							Number of ports
							Item
M12 4-pin connector type		No-mark	5m				
M12 5-pin connector type		5	5m				
		10	10m				
		No-mark	4-pin				
		5	5-pin				
		N	NPN type				
		P	PNP type				
		2D	DC 2-wire (1-signal)				
		3D	DC 3-wire (1-signal)				
		4D	DC 4-wire (1-signal, 2-signal)				
		No-mark	Cable type				
		C	Connector type				
		4	4EA				
		6	6EA				
		8	8EA				
		PT	Sensor distribution box				

※1: It is not applied for DC 2-wire (1-signal) type of output.
 ※2: Cable length is only for Cable type models.

■ Specifications

Type	M12 4-pin connector type			M12 5-pin connector type						
Model	Cable type	PT4-2D□	PT6-2D□	PT8-2D□	PT4-3D□5□	PT4-4D□5□	PT6-3D□5□	PT6-4D□5□	PT8-3D□5□	PT8-4D□5□
	Connector type	PT4-3D□	PT6-3D□	PT8-3D□	PT4-C3D□5	PT4-C4D□5	PT6-C3D□5	PT6-C4D□5	PT8-C3D□5	PT8-C4D□5
Port	4EA	6EA	8EA	6EA						
Output type*1	2-wire (1-signal), 3-wire (1-signal)			3-wire (1-signal)	4-wire (2-signal)	3-wire (1-signal)	4-wire (2-signal)	3-wire (1-signal)	4-wire (2-signal)	
Power supply	12-24VDC (10-30VDC)									
Rated current	2A (per signal), 4A (per port), 10A (total)									
Leakage current	Max. 0.5mA									
Connection life cycle	Min. 200 operations									
Cable tensile strength	10kgf (98N)/15S									
Insulation resistance	Min. 50MΩ (at 500VDC megger)									
Dielectric strength	1500VAC 50/60Hz for 1minute									
Vibration	1mm amplitude at frequency of 10 to 55Hz (for 1 min.) in each X, Y, Z direction for 2 hours									
Shock	500m/s ² (approx. 50G) in each X, Y, Z direction for 3 times									
Indicator	Power indicator: Green, Operation indicator: Red					Power indicator: Red, Operation indicator: Green				
Environment	Ambient temp.	-25 to 75, storage: -30 to 80								
	Ambient humi.	35 to 95%RH, storage: 35 to 95%RH			35 to 85%RH, storage: 35 to 85%RH					
Protection structure*2	IP67 (IEC standards/when mounting connector, waterproof cover) or IP52 (IEC standards/when mounting protection cover)									
Material	Case: PBT (G15%), General cable (gray): Polyvinyl chloride (PVC)					Case: PBT (G15%), Name plate: PC, General cable (black): Polyvinyl chloride (PVC)				
Weight*3	Cable type*4	Approx. 700g (Approx. 660g)	Approx. 720g (Approx. 680g)	Approx. 820g (Approx. 780g)	Approx. 1100g (Approx. 900g)	Approx. 1400g (Approx. 1200g)	Approx. 1130g (Approx. 930g)	Approx. 1430g (Approx. 1230g)	Approx. 1160g (Approx. 960g)	Approx. 1460g (Approx. 1260g)
	Connector type				Approx. 230g (Approx. 120g)	Approx. 235g (Approx. 125g)	Approx. 260g (Approx. 150g)	Approx. 265g (Approx. 155g)	Approx. 290g (Approx. 180g)	Approx. 295g (Approx. 185g)

※1: Connect the sensor to the proper output type. ※2: This is not applicable when connectors and protection/waterproof covers are not mounted.
 ※3: The weight includes packaging. The weight in parentheses is for unit only. ※4: The weights are for 5m cable.
 ※Environment resistance is rated at no freezing or condensation.

Sensor Distribution Box

(unit: mm)

Dimensions

※The below dimensions are based on 8-port.

● M12 4-pin connector type

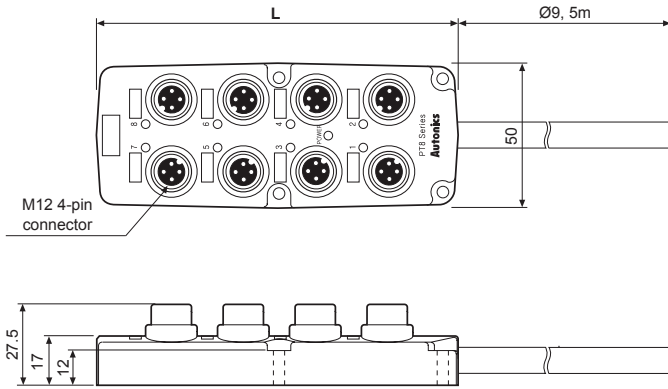

Model	L
PT4-□□	73
PT6-□□	98
PT8-□□	123

※Cable specification:
Ø9, 10-wire (conductor
cross section: 0.3mm²,
insulator diameter: Ø1.67)

● Panel cut-out

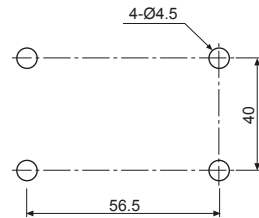

※Mounting holes are same as 4, 6, 8-port.

● M12 5-pin connector type

- Cable type

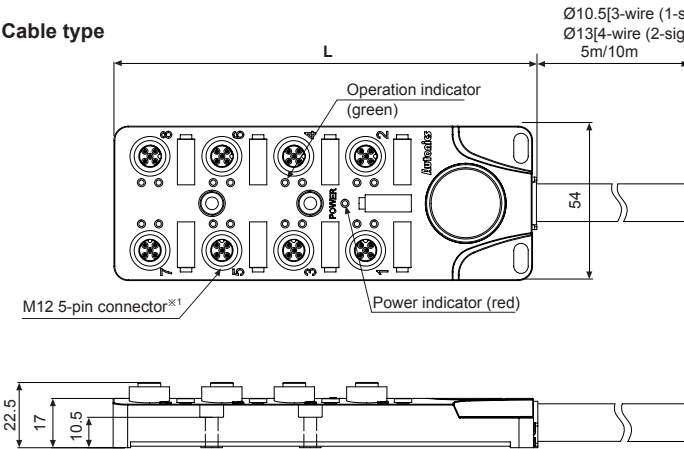

Model	L
PT4-□□□□□	95
PT6-□□□□□	120
PT8-□□□□□	145

● Panel cut-out

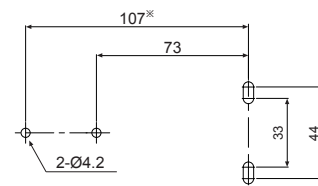

※Except 4-port model.

※1: "When connecting L type connectors, connection direction may be different by the manufacturers of the connector."

- Connector type

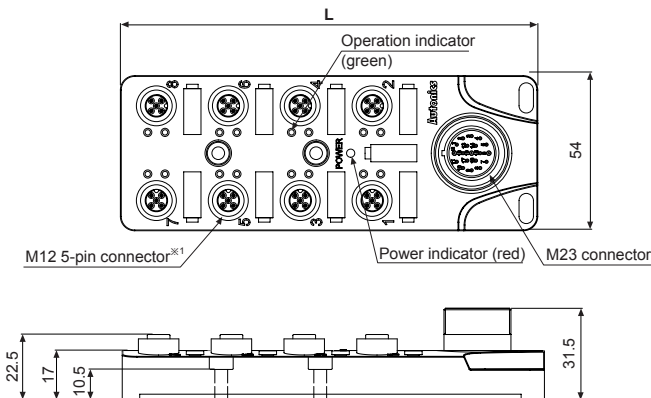

Model	L
PT4-C□□□□	95
PT6-C□□□□	120
PT8-C□□□□	145

● Panel cut-out

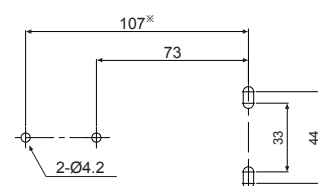

※Except 4-port model.

※1: "When connecting L type connectors, connection direction may be different by the manufacturers of the connector."

(A)	Photoelectric Sensors
(B)	Fiber Optic Sensors
(C)	Door/Area Sensors
(D)	Proximity Sensors
(E)	Pressure Sensors
(F)	Rotary Encoders
(G)	Connectors/ Sockets
(H)	Temperature Controllers
(I)	SSRs / Power Controllers
(J)	Counters
(K)	Timers
(L)	Panel Meters
(M)	Tacho / Speed / Pulse Meters
(N)	Display Units
(O)	Sensor Controllers
(P)	Switching Mode Power Supplies
(Q)	Stepper Motors & Drivers & Controllers
(R)	Graphic/ Logic Panels
(S)	Field Network Devices
(T)	Software

PT Series

■ Sold Separately

(unit: mm)

- Protection cover (CAP-PT)

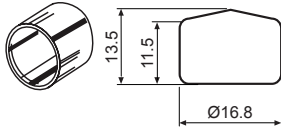

※This protection cover is used for protecting connection holes from dust or particle, etc. Please push it into hole.

※If using protection covers, protection structure of the sensor distribution box is IP52.

- Waterproof cover (P96-M12-1)

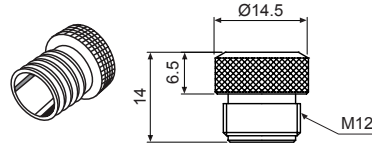

※This waterproof cover is used for protecting unused connection hole from water or oil, etc. Please tighten it when applying to the ports.

※If using waterproof covers, protection structure of the sensor distribution box is IP67.

- M23 connector cable (only for M12 5-pin connector type)

	12-pin[3-wire (1-signal)]			19-pin[4-wire (2-signal)]			
Model	CLDH12C -040	CLDH12C -060	CLDH12C -080	CLDH19C -040	CLDH19C -060	CLDH19C -080	
Dimensions							(unit: mm)
Pin arrangement							
Cable length ^{※1}	4m	6m	8m	4m	6m	8m	
Applied model	PT4-C3DN5, PT4-C3DP5, PT6-C3DN5, PT6-C3DP5, PT8-C3DN5, PT8-C3DP5			PT4-C4DN5, PT4-C4DP5, PT6-C4DN5, PT6-C4DP5, PT8-C4DN5, PT8-C4DP5			
Connection cable	Pin no.	Cable color	AWG	Pin no.	Cable color	AWG	
	1	White	AWG22	1	Purple	AWG22	
	2	Green		2	Red		
	3	Yellow		3	Gray		
	4	Gray		4	Red/Blue		
	5	Pink		5	Green	AWG17	
	6	Red		6	Blue		
	7	Black		7	Gray/Pink		
	8	Purple		8	White/Green		
	9	Blue	AWG17	9	White/Yellow	AWG22	
	10	-		10	White/Gray		
	11	Brown		11	Black		
	12	Green/Yellow		12	Green/Yellow	AWG17	
				13	Yellow/Brown		
				14	Brown/Green	AWG22	
				15	White		
				16	Yellow		
				17	Pink		
				18	Gray/Brown		
		19		Brown	AWG17		

※1: Cable length can be customized.

Sensor Distribution Box

Example of Connections

● Connection with connector type sensor

When connecting a connector type proximity sensor (PRCM Series) with a sensor distribution box, use only connector cable.

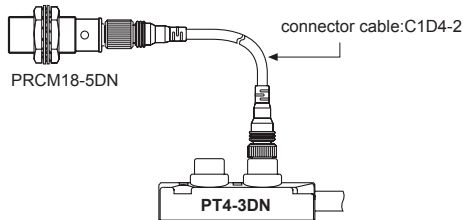

● Connection with cable type sensor

It is available to connect a cable type sensor proximity sensor (PRW Series) with a sensor distribution box directly. When installation distance is longer, use a connector cable.

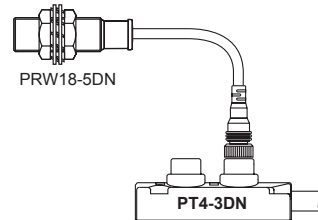

Connectable Autonics Proximity Sensors, Photoelectric Sensors, Door/Area Sensors

Sensor distribution box	Input logic	Proximity sensor	Photoelectric sensor	Door/Area sensor	Connection method	
PT□-2D	DC 2-wire	PRCMT12-2/4DO, DC PRCMT18-5/8DO, DC PRCMT30-10/15DO, DC	PRDCMT12-4/8DO,DC PRDCMT18-7/14DO,DC PRDCMT30-15/25DO,DC	—	Use connector cable	
		PRWT12-2/4DO, DC PRWT18-5/8DO, DC PRWT30-10/15DO, DC	PRDWT12-4/8DO,DC PRDWT18-7/14DO,DC PRDWT30-15/25DO,DC		Connect directly, Use connector cable	
PT□-3DN PT□-3DN5-□ PT□-□3DN5	DC 3-wire NPN output type	PRCM12-2/4DN, DN2 PRCM18-5/8DN, DN2 PRCM30-10/15DN, DN2 PRCML18-5/8DN, DN2 PRCML30-10/15DN, DN2	PRDCM12-4/8DN, DN2 PRDCM18-7/14DN, DN2 PRDCM30-15/25DN, DN2 PRDCML12-4/8DN, DN2 PRDCML18-7/14DN, DN2 PRDCML30-15/25DN, DN2	BRP3M-MDT-C BR3M-MDT-C	Use connector cable	
		PRW12-2/4DN, DN2 PRW18-5/8DN, DN2 PRW30-10/15DN, DN2 PRWL18-5/8DN, DN2 PRWL30-10/15DN, DN2	PRDW12-4/8DN, DN2 PRDW18-7/14DN, DN2 PRDW30-15/25DN, DN2 PRDWL12-4/8DN, DN2 PRDWL18-7/14DN, DN2 PRDWL30-15/25DN, DN2	—	Connect directly, Use connector cable	
PT□-3DP PT□-3DP5-□ PT□-□3DP5	DC 3-wire PNP output type	PRCM12-2/4DP, DP2 PRCM18-5/8DP, DP2 PRCM30-10/15DP, DP2 PRCML18-5/8DP, DP2 PRCML30-10/15DP, DP2	PRDCM12-4/8DP, DP2 PRDCM18-7/14DP, DP2 PRDCM30-15/25DP, DP2 PRDCML12-4/8DP, DP2 PRDCML18-7/14DP, DP2 PRDCML30-15/25DP, DP2	BRP3M-MDT-C-P BR3M-MDT-C-P	Use connector cable	
		PRW12-2/4DP, DP2 PRW18-5/8DP, DP2 PRW30-10/15DP, DP2 PRWL18-5/8DP, DP2 PRWL30-10/15DP, DP2	PRDW12-4/8DP, DP2 PRDW18-7/14DP, DP2 PRDW30-15/25DP, DP2 PRDWL12-4/8DP, DP2 PRDWL18-7/14DP, DP2 PRDWL30-15/25DP, DP2	—	Connect directly, Use connector cable	
PT□-4DN5-□ PT□-□4DN5	DC 4-wire NPN output type	—	—	BRP100-DDT-C BR100DDT-C BRP400DDT-C BR400DDT-C BRP200DDTN-C BR200DDTN-C	BWC40-□H, HD BWC80-□H, HD BW20-□ BW40-□	Connect directly, Use connector cable
		—	—	BRP100-DDT-C-P BR100-DDT-C-P BRP400DDT-C-P BR400DDT-C-P BRP200DDTN-C-P BR200DDTN-C-P	BW20-□P BW40-□P	Connect directly, Use connector cable

※Standard cable type sensors can also connect a sensor distribution box by using plug type connector cable.

- (A) Photoelectric Sensors
- (B) Fiber Optic Sensors
- (C) Door/Area Sensors
- (D) Proximity Sensors
- (E) Pressure Sensors
- (F) Rotary Encoders
- (G) Connectors/ Sockets
- (H) Temperature Controllers
- (I) SSRs / Power Controllers
- (J) Counters
- (K) Timers
- (L) Panel Meters
- (M) Tacho / Speed / Pulse Meters
- (N) Display Units
- (O) Sensor Controllers
- (P) Switching Mode Power Supplies
- (Q) Stepper Motors & Drivers & Controllers
- (R) Graphic/ Logic Panels
- (S) Field Network Devices
- (T) Software

■ Connections

● M12 4-pin connector type

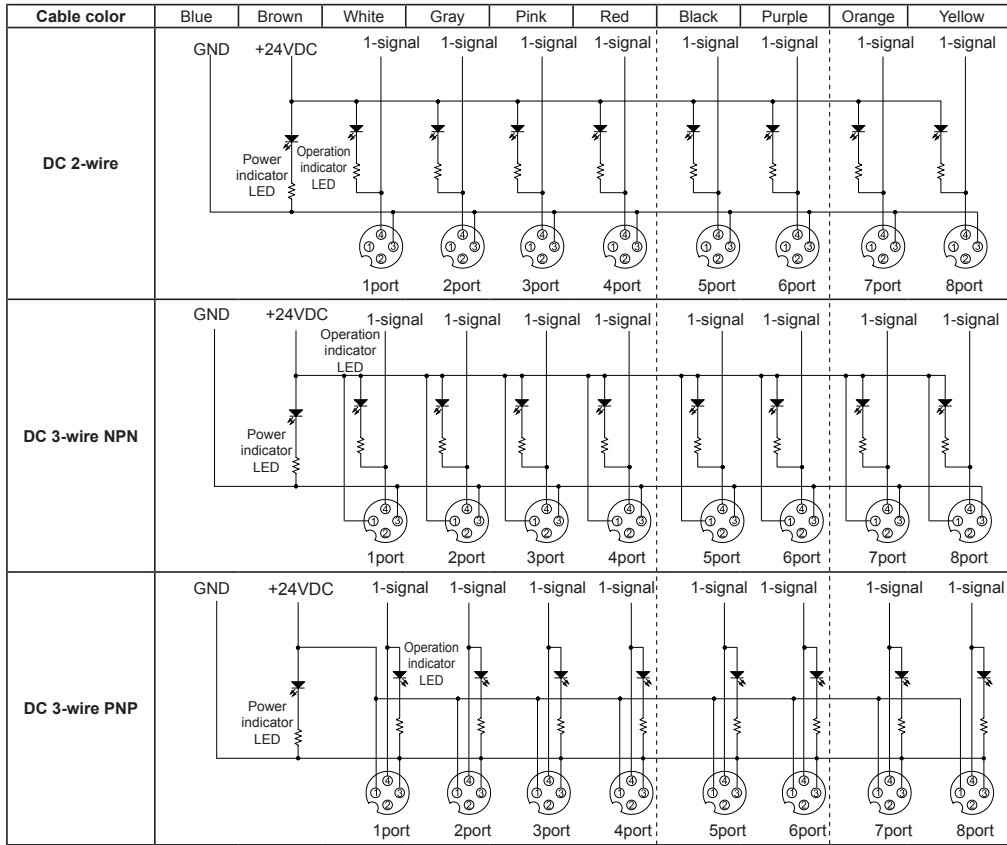

● M12 5-pin connector type

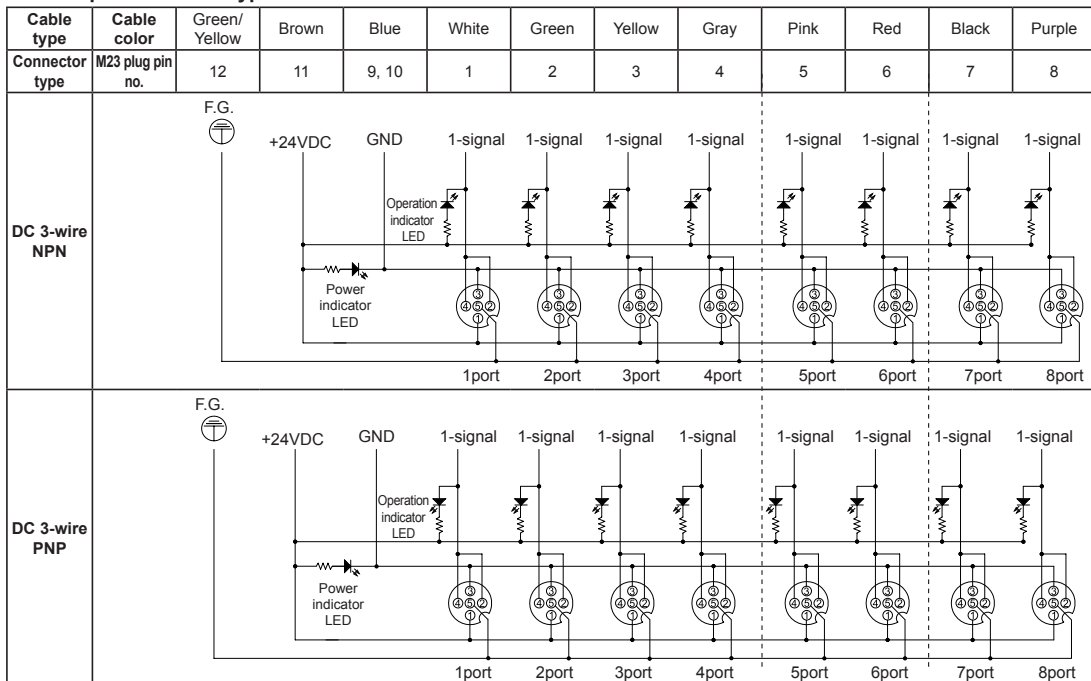

Sensor Distribution Box

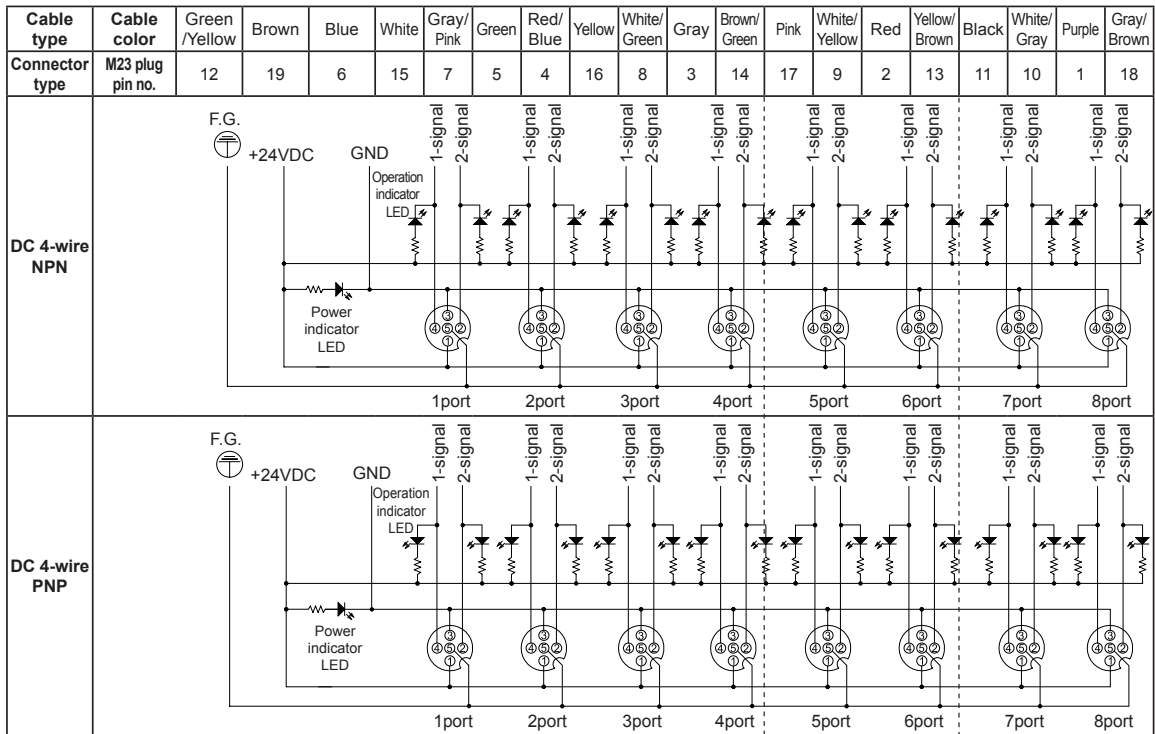

- (A) Photoelectric Sensors
- (B) Fiber Optic Sensors
- (C) Door/Area Sensors
- (D) Proximity Sensors
- (E) Pressure Sensors
- (F) Rotary Encoders
- (G) Connectors/ Sockets**
- (H) Temperature Controllers
- (I) SSRs / Power Controllers
- (J) Counters
- (K) Timers
- (L) Panel Meters
- (M) Tacho / Speed / Pulse Meters
- (N) Display Units
- (O) Sensor Controllers
- (P) Switching Mode Power Supplies
- (Q) Stepper Motors & Drivers & Controllers
- (R) Graphical/ Logic Panels
- (S) Field Network Devices
- (T) Software

■ Caution During Use

1. This connection box is only for DC. Do not use this unit for AC.
2. Use DC 2-wire, DC 3-wire, DC 4-wire separately.
DC 3-wire, DC 4-wire are separated by NPN type and PNP type.
3. Do not use the same conduit with cord of this unit and electric power line and power line. Also avoid the same connection.
4. Be sure that wire power cable (blue: -, brown: +) properly.
5. Check the voltage variation range of power not to over the rated specifications for power input.
6. In case of M12 5-pin connector type, Tighten the screws and connector with the proper tightening strength.
(M4 mounting screw: max. 1.2N.m / M12 Connector: 0.6 to 0.7N.m/ M23 Connector: 2.0 to 2.5N.m)
When tightening is bad, protection is not effective and it may loose by vibration.
7. In case of M12 4-pin connector type, the power indicator (green LED) does not operate when polarity is not correctly connected.
8. If transceiver is close to wire connections, it may cause malfunction.
9. When take out the connector from the box, cut off the power.
10. It might cause malfunction, if particle of metal etc. inflow in to engaging.
11. Do not use this unit when external force loaded on contact block and connection of cover. It may cause loss of efficiency of protection.
12. Follow the connections when wiring the signals. After connecting loads, operate proximity sensors.
13. Check the operation indicator when operating the sensors.
14. Please use protection cover (CAP-PT, sold separately) or water-proof cover (P96-M12-1, sold separately) for not using connector (M12 Socket).
15. Do not use in place there are water or oil etc.
16. Main body is made by plastic, therefore do not put heavy load on this product.
17. Please avoid below environment for long-term storage.
 - ① Lots of dust or high humidity
 - ② Ammonia or sulfide gas