

# MT4N Series

## DIN W48×H24mm Small Size Digital Multi Panel Meter

### ■ Features

- Various output options (Default: Indicator) RS485 communication output, current (DC4-20mA), NPN/PNP open collector output, relay contact output
- Max. measuring inputs  
: 50VDC, 250VAC, DC500mA, AC5A
- Display range: -1999 to 9999
- High/Low scale function for high performance
- **AC frequency measurement: Range 0.1 to 9999Hz**
- Various functions: Monitoring function for max. and min. display value function, display cycle delay function, zero function, high display correction function, current output scale function
- Power supply: 12-24VDC/VAC, 100-240VAC



⚠ Please read "Caution for your safety" in operation manual before using.



### ■ Ordering Information

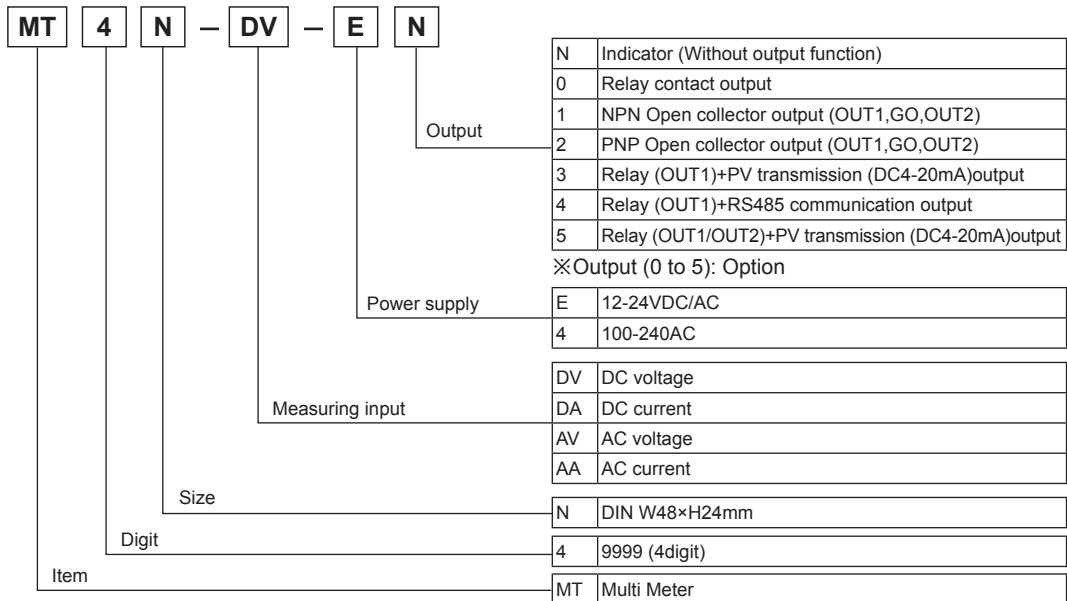

※To measure the current over 5ADC, please select DV type because the shunt should be used.

### ■ Unit Description

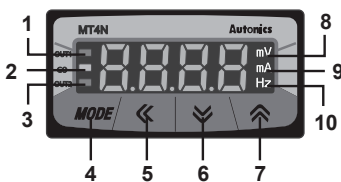

1. **OUT1**: Preset output of OUT1
2. **GO**: Preset Go output of OUT1/OUT2
3. **OUT2**: Preset output of OUT2
4. **MODE** key: Mode key
5. **←**: Shift key
6. **↓**: Down key
7. **↑**: Up key
8. **mV, V** unit
9. **mA, A** unit
10. **Hz** unit

※There is no 1, 2, 3 on a display panel of MT4N-□-□N.  
 ※MT4N-□-□3, □4 model has output display part of OUT1 only.

## Specifications

Series	MT4N-DV-E□ MT4N-DA-E□	MT4N-AV-E□ MT4N-AA-E□	MT4N-DV-4□ MT4N-DA-4□	MT4N-AV-4□ MT4N-AA-4□
Measurement input	DC voltage, current	AC voltage, current, frequency	DC voltage, current	AC voltage, current, frequency
Power supply	12-24VDC/AC		100-240VAC	
Allowable voltage range	90 to 110%			
Power consumption	DC: 3W, AC: 5VA / For MT4N-□□-E5 - DC: 5W, AC: 8VA		5VA	
Display method	7Segment LCD display, Character height: 9mm			
Display accuracy	• 23°C±5°C - DC type: F.S. ±0.1% rdg ±2digit / AC type: F.S. ±0.3% rdg ±3digit DC/AC type: F.S. +0.3% rdg +3digit max. only for 5A terminal. • -10°C to 50°C - DC/AC type: F.S. ±0.5% rdg ±3digit			
Max. allowable input	110% F.S. for each measured input range			
A/D conversion method	Practical oversampling using successive approximation ADC			
Sampling cycle	DC type: 50ms, AC type: 16.6ms			
Max. display range	-1999 to 9999 (4digit)			
Preset output	• Relay output - Contact capacity: 125VAC 0.3A, 30VDC 1A/Contact composition: N.O (1a) • NPN/PNP Open Collector output - Max. 12-24VDC ±2V 50mA (Load resistance)			
Sub output (Transmission output)	• RS485 communication output - Baud rate: 1200/2400/4800/9600, Communication method : 2 wires half duplex, Synchronous method: Sub-synchronization, Protocol: Modbus type • DC4-20mA output - Resolution: 12,000 division (Load resistance max. 600Ω)			
AC measuring function※1	Selectable RMS or AVG			
Frequency measuring function※1	Measurement range: 0.100 to 9999Hz (Differ according to decimal point position)			
Hold function※2	Includes (Outer hold function)			
Insulation resistance	Min. 20MΩ (at 500VDC megger)			
Dielectric strength	1000VAC for 1 minute (Between external terminal and case)		2000VAC for 1 minute (Between external terminal and case)	
Noise strength	±2kV the square wave noise (pulse width: 1μs) by the noise simulator			
Vibration	Mechanical	0.75mm amplitude at frequency of 10 to 55Hz (for 1 min.) in each X, Y, Z direction for 2 hours		
	Malfunction	0.5mm amplitude at frequency of 10 to 55Hz (for 1 min.) in each X, Y, Z direction for 10 minutes		
Shock	Mechanical	100m/s <sup>2</sup> (approx. 10G) in each X, Y, Z direction for 3 times		
	Malfunction	300m/s <sup>2</sup> (approx. 30G) in each X, Y, Z direction for 3 times		
Environment	Ambient temperature	-10 to 50°C, storage: -20 to 60°C		
	Ambient humidity	35 to 85%RH, storage: 35 to 85%RH		
Insulation type	Double insulation or reinforced insulation (Mark: □, dielectric strength between the measuring input part and the power part: 1kV)			
Approval	CE		—	
Weight※3	Approx. 125g (approx. 64g)			

※1: AC measuring function, and frequency measuring function are only for AC measuring input type. ※2: The indicator has no Hold function.  
 ※3: The weight includes packaging. The weight in parentheses is for unit only. ※Environment resistance is rated at no freezing or condensation.

## Connections

### Measuring input terminal connection

#### MT4N-DV-□□

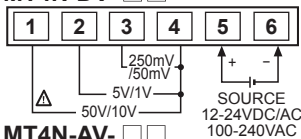

#### MT4N-AV-□□

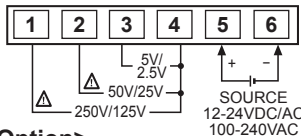

#### MT4N-DA-□□

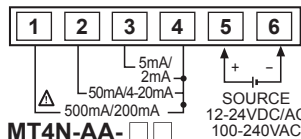

#### MT4N-AA-□□

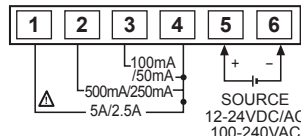

### <Option>

#### Relay output

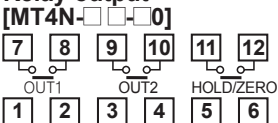

#### NPN open collector output

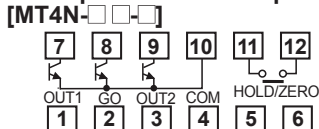

#### PNP open collector output

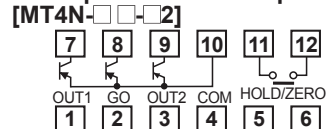

#### Relay+Current (DC4-20mA) output

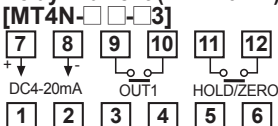

#### Relay+RS485 communication output

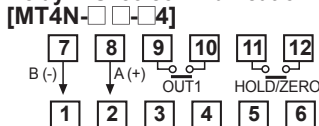

#### Relay 2+Current (DC4-20mA) output

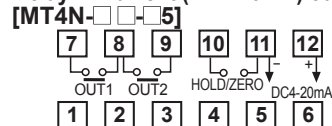

(A)	Photoelectric Sensors
(B)	Fiber Optic Sensors
(C)	Door/Area Sensors
(D)	Proximity Sensors
(E)	Pressure Sensors
(F)	Rotary Encoders
(G)	Connectors/ Sockets
(H)	Temperature Controllers
(I)	SSRs / Power Controllers
(J)	Counters
(K)	Timers
(L)	Panel Meters
(M)	Tacho / Speed / Pulse Meters
(N)	Display Units
(O)	Sensor Controllers
(P)	Switching Mode Power Supplies
(Q)	Stepper Motors & Drivers & Controllers
(R)	Graphic/ Logic Panels
(S)	Field Network Devices
(T)	Software

# MT4N Series

## ■ Dimensions

### ● MT4N-□□□-□N

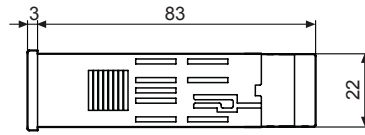
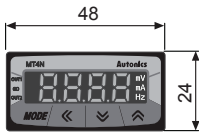

### ● MT4N-□□□-□0



### ● MT4N-□□□-□1, □2



### ● MT4N-□□□-□3, □4



### ● Panel cut-out

(unit: mm)

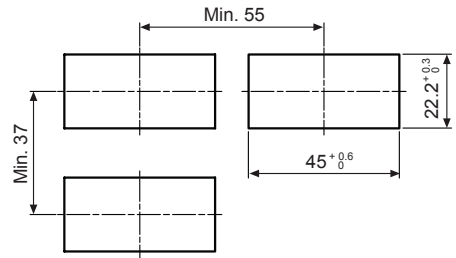

※Process the unit after consider the above recommended cut-out fully.

## ■ Parameter Group

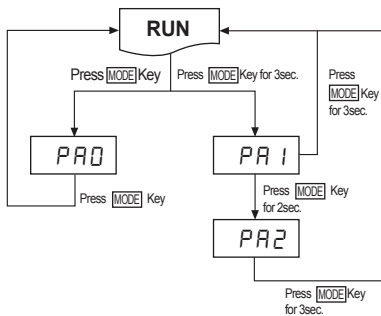

- ※Press **[MODE]** key in **RUN** status, it will advance to **[PA0]** (Parameter 0) group.
- ※Press **[MODE]** key for 2 sec. in **RUN** mode, **[PA1]** is displayed.
- ※Press **[MODE]** key for 4 sec. in **RUN** mode, **[PA1]** is displayed after **[PA2]**. When pressing **[MODE]** key continually, it stops displaying at **[PA2]**.
- ※It is advanced to current display parameter releasing **[MODE]** key at **[PA1]** or **[PA2]**.
- ※Press **[MODE]** key for 3 sec., it is returned to **RUN** at any position.
- ※If any key is not touched for 60 sec. in each parameter, it returns to **RUN** mode.
- ※After return to **RUN** mode, press **[MODE]** key within 2 sec., it returns to previous parameter. (Refer to the below descriptions for set parameter.)
- ※It cannot advance to **[PA0]** when preset output operation mode of **[PA2]** is **OFF**.

## ■ Change The Parameter Setting Value

1. Advance to the parameter to be changed when pressing **[MODE]** key continuously in **RUN** mode and releasing **[MODE]** key at the parameter.  
(Refer to "■Parameter setting".)
2. When pressing **[MODE]** key in each parameter, the initial mode of the parameter is displayed.  
(Refer to the description of each parameter.)
3. When pressing one of **[←]**, **[↓]**, **[↑]** keys in display mode, saved setting value is displayed.

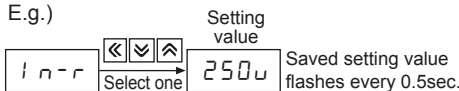

4. Change the setting value by **[↑]** or **[↓]** key when setting value flashes.

E.g.) Change AC type measuring input from 250V to 125V.

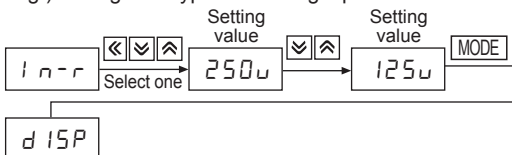

5. When confirming the setting value with **[MODE]** key, the changed setting value flashes twice and enters into the next setting.
6. It returns **RUN** mode from parameter by pressing **[MODE]** key for 3 sec.

## Parameter 1 Group

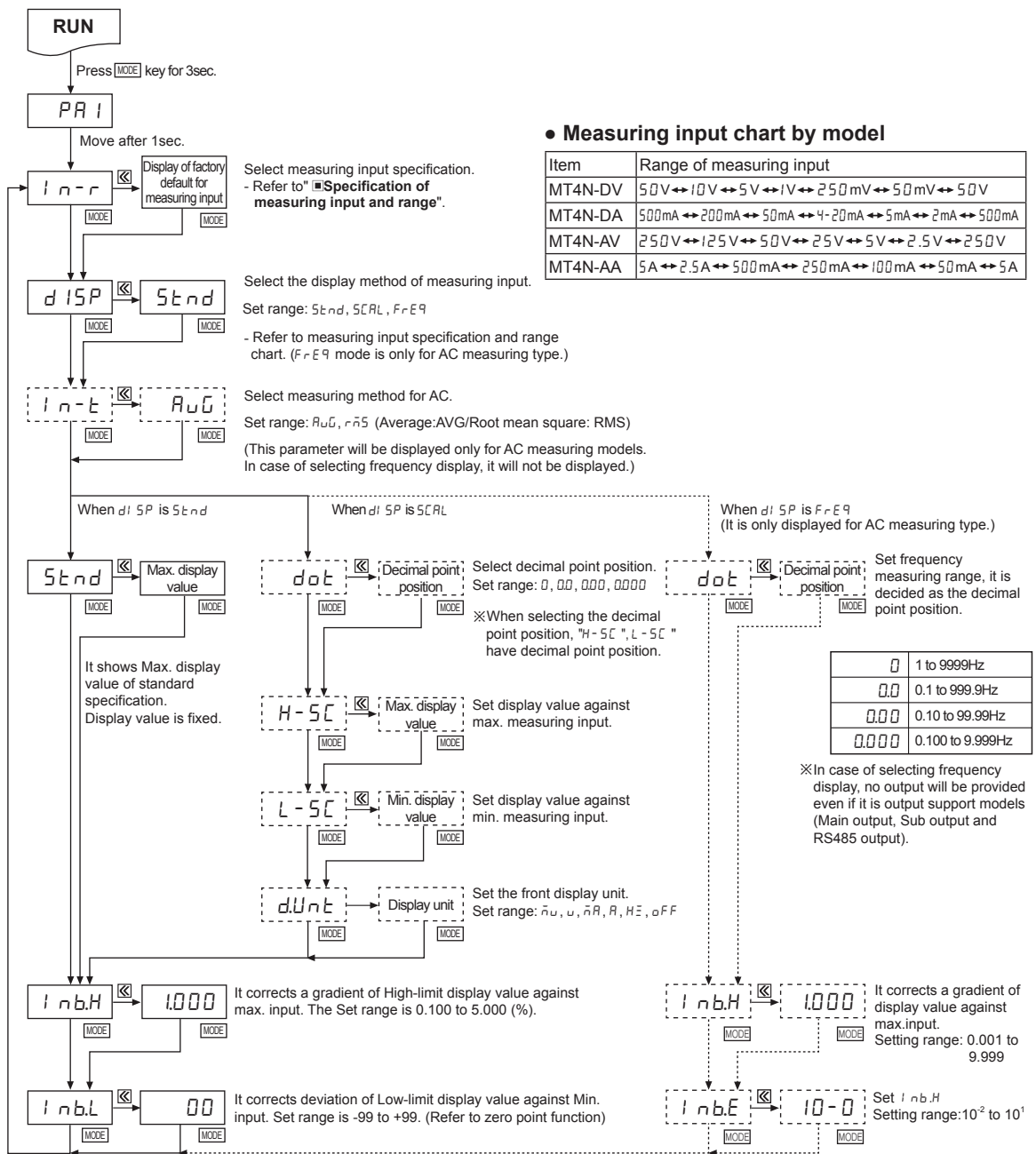

※After setting each mode, press **MODE** key for 2sec. to return to RUN.

※If any key is untouched for 60sec. after advance to Parameter, it will return to RUN.

### Factory defaults

Parameter	MT4N-DV	MT4N-DA	MT4N-AV	MT4N-AA	Parameter	MT4N-DV	MT4N-DA	MT4N-AV	MT4N-AA
In-r	50	500	250	5	Inb.H	1.000	1.000	1.000	1.000
dISP	Stnd	Stnd	Stnd	Stnd	Inb.L	00	00	00	00
In-t	—	—	AuG	AuG	dot	0.00	0.0	0.0	0.000
Stnd	50.00	500.0	250.0	5.000	Inb.E	—	—	10-0	10-0
d-Unit	u	R	u	R					

(A) Photoelectric Sensors

(B) Fiber Optic Sensors

(C) Door/Area Sensors

(D) Proximity Sensors

(E) Pressure Sensors

(F) Rotary Encoders

(G) Connectors/ Sockets

(H) Temperature Controllers

(I) SSRs / Power Controllers

(J) Counters

(K) Timers

(L) Panel Meters

(M) Tacho / Speed / Pulse Meters

(N) Display Units

(O) Sensor Controllers

(P) Switching Mode Power Supplies

(Q) Stepper Motors & Drivers & Controllers

(R) Graphic/ Logic Panels

(S) Field Network Devices

(T) Software

# MT4N Series

## Parameter 2 Group

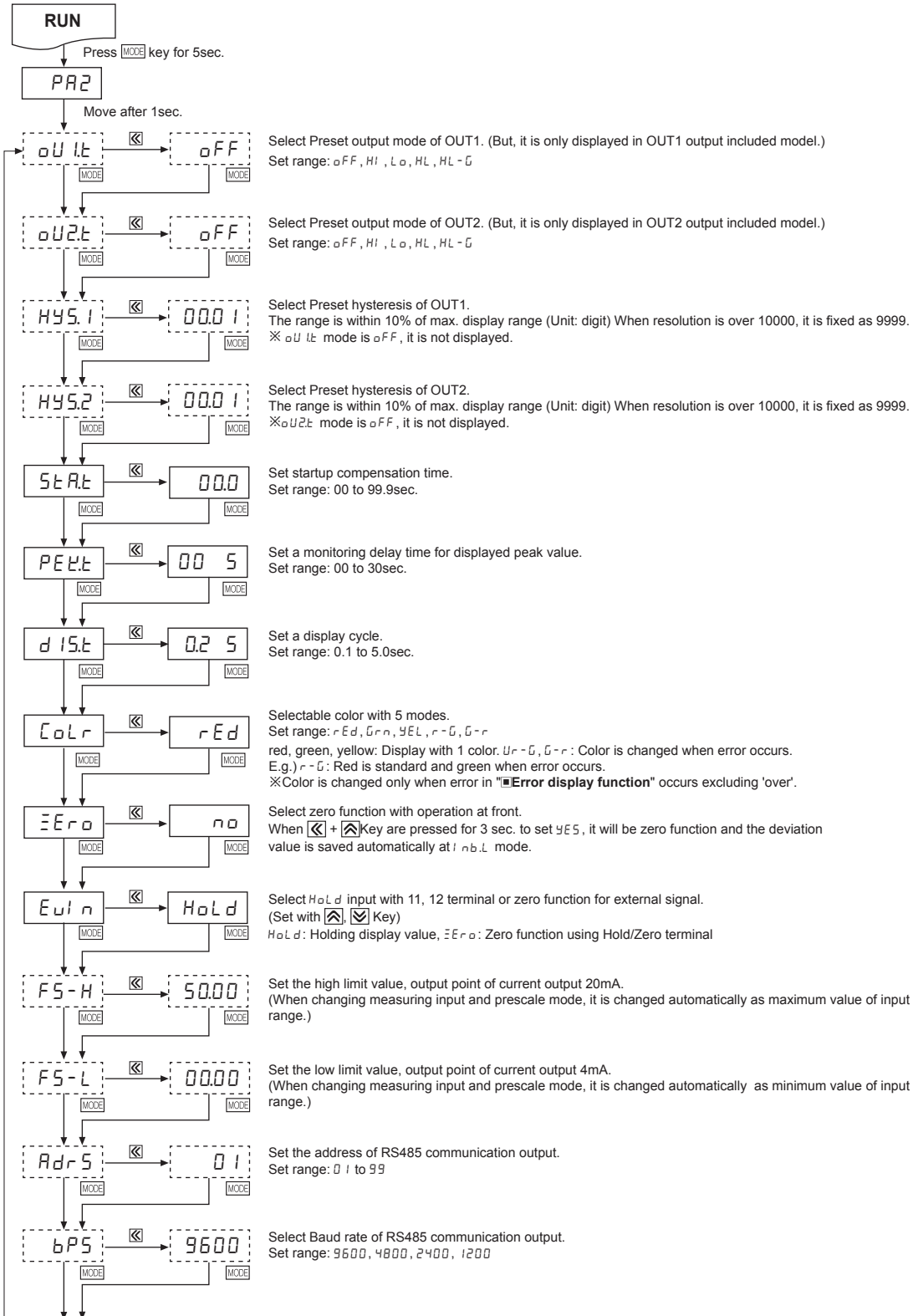

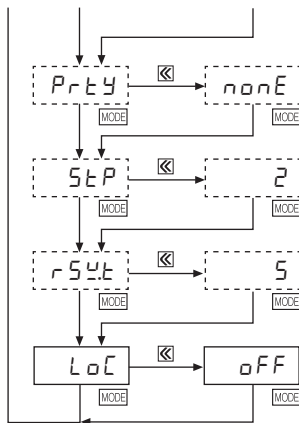

Set parity bit of RS485 communication.  
Set range: nonE, EvEn, odd

Set stop bit of RS485 communication.  
Set range: 1, 2

Set response wait time of RS485 communication.  
Set range: 5 to 99

Set key lock function and select from 4 types.  
Set range: oFF, LoC1, LoC2, LoC3

oFF	Disable to lock keys
LoC1	Lock Parameter 1
LoC2	Lock Parameter 1, 2
LoC3	Lock Parameter 0, 1 and 2

※The dotted mode is only displayed for output type.

※After setting each mode, press **MODE** key for 2sec. to return to **RUN** mode.

※If any key is untouched for 60sec. after advance to PARAMETER, it will return to **RUN** mode.

※The min. setting interval between F5-H and F5-L is 10% FUS, it is fixed as 10% of the setting value when it is small.

## ◎ Factory defaults

Parameter	MT4N-DV	MT4N-DA	MT4N-AV	MT4N-AA	Parameter	MT4N-DV	MT4N-DA	MT4N-AV	MT4N-AA
oU1.t	oFF	oFF	oFF	oFF	Erro	no	no	no	no
oU2.t	oFF	oFF	oFF	oFF	EvIn	HoLd	HoLd	HoLd	HoLd
HYS.1	00.01	000.1	000.1	0.001	F5-H	50.00	50.00	25.00	50.00
HYS.2	00.01	000.1	000.1	0.001	F5-L	00.00	00.00	00.00	00.00
PEt.t	00.5	00.5	00.5	00.5	AdrS	01	01	01	01
d1St	02.5	02.5	02.5	02.5	bPS	9600	9600	9600	9600
CoLr	rEd	rEd	rEd	rEd	LoC	oFF	oFF	oFF	oFF

## ■ Parameter 0 Group

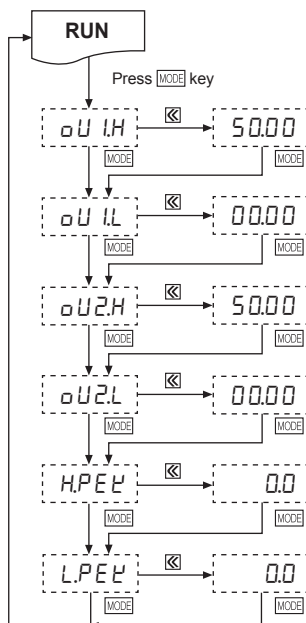

Set High-limit preset value of oU1H. (Set with **◀**, **▶**, **↵** key)  
※It is displayed when set the preset only.

When set oFF in oU1.t mode if PA-2, the parameter is not displayed.

Set Low-limit preset value of oU1L. (Set with **◀**, **▶**, **↵** key)  
※It is displayed when set the preset only.

When set oFF in oU1.t mode if PA-2, the parameter is not displayed.

Set High-limit preset value of oU2H. (Set with **◀**, **▶**, **↵** key)  
※It is displayed when set the preset only.

When set oFF in oU2.t mode if PA-2, the parameter is not displayed.

Set Low-limit preset value of oU2L. (Set with **◀**, **▶**, **↵** key)  
※It is displayed when set the preset only.

When set oFF in oU2.t mode if PA-2, the parameter is not displayed.

It shows High-limit monitoring value while it is **RUN** status.  
It will be reset by pressing any **◀**, **▶**, **↵** key.

※HPEt parameter is not displayed when PEt.t parameter is set as 00 sec.[00.5] at Parameter 2 group.

It shows Low-limit monitoring value while it is **RUN** status.  
It will be reset by pressing any **◀**, **▶**, **↵** key.

※LPEt parameter is not displayed when PEt.t parameter is set as 00 sec.[00.5] at Parameter 2 group.

※If any key is untouched for 60sec. after advance to Parameter, it will return to **RUN** mode.

## ◎ Factory defaults

Mode	MT4N-DV	MT4N-DA	MT4N-AV	MT4N-AA	Mode	MT4N-DV	MT4N-DA	MT4N-AV	MT4N-AA
oU1H	50.00	500.0	250.0	5.000	oU2L	00.00	500	000.0	0.000
oU1L	00.00	000.0	000.0	0.000	HPEt	0.00	0.0	0.0	0.000
oU2H	50.00	500.0	250.0	5.000	LPEt	0.00	0.0	0.0	0.000

- (A) Photoelectric Sensors
- (B) Fiber Optic Sensors
- (C) Door/Area Sensors
- (D) Proximity Sensors
- (E) Pressure Sensors
- (F) Rotary Encoders
- (G) Connectors/ Sockets
- (H) Temperature Controllers
- (I) SSRs / Power Controllers
- (J) Counters
- (K) Timers
- (L) Panel Meters
- (M) Tacho / Speed / Pulse Meters
- (N) Display Units
- (O) Sensor Controllers
- (P) Switching Mode Power Supplies
- (Q) Stepper Motors & Drivers & Controllers
- (R) Graphic/ Logic Panels
- (S) Field Network Devices
- (T) Software

## ■ Specification Of Measuring Input And Range

Type	Measuring input and range	Input impedance	Display range [Set nd]	Prescale display range [SCAL]										
DC voltage	0-50V [50V]	434.35kΩ	0.00 to 50.00 (fixed)	<table border="1"> <thead> <tr> <th>dot</th> <th>Display range</th> </tr> </thead> <tbody> <tr> <td>0</td> <td>-1999 to 9999</td> </tr> <tr> <td>0.0</td> <td>-199.9 to 999.9</td> </tr> <tr> <td>0.00</td> <td>-19.99 to 99.99</td> </tr> <tr> <td>0.000</td> <td>-1.999 to 9.999</td> </tr> </tbody> </table> <p>(Display range depends on the decimal point position.)</p> <p>※Please connect proper terminal its max. input voltage is within 30 to 100% of input terminal. When it is higher than input voltage, it may cause a breakdown of terminal and over display range and the accuracy is decreased when it is connected to the terminal under 30%.</p>	dot	Display range	0	-1999 to 9999	0.0	-199.9 to 999.9	0.00	-19.99 to 99.99	0.000	-1.999 to 9.999
	dot	Display range												
	0	-1999 to 9999												
	0.0	-199.9 to 999.9												
	0.00	-19.99 to 99.99												
	0.000	-1.999 to 9.999												
0-10V [10V]	434.35kΩ	0.00 to 10.00 (fixed)												
0-5V [5V]	43.35kΩ	0.000 to 5.000 (fixed)												
0-1V [1V]	43.35kΩ	0.000 to 1.000 (fixed)												
0-250mV [250mV]	2.15kΩ	0.0 to 250.0 (fixed)												
0-50mV [50mV]	2.15kΩ	0.00 to 50.00 (fixed)												
DC current	0-500mA [500mA]	0.1Ω	0.0 to 500.0 (fixed)											
	0-200mA [200mA]	0.1Ω	0.0 to 200.0 (fixed)											
	0-50mA [50mA]	1.1Ω	0.00 to 50.00 (fixed)											
	4-20mA [4-20mA]	1.1Ω	4.00 to 20.00 (fixed)											
	0-5mA [5mA]	101.1Ω	0.000 to 5.000 (fixed)											
	0-2mA [2mA]	101.1Ω	0.000 to 2.000 (fixed)											
AC voltage	0-250V [250V]	1.109MΩ	0.0 to 250.0 (fixed)											
	0-125V [125V]	1.109MΩ	0.0 to 125.0 (fixed)											
	0-50V [50V]	200kΩ	0.00 to 50.00 (fixed)											
	0-25V [25V]	222kΩ	0.00 to 25.00 (fixed)											
	0-5V [5V]	222kΩ	0.000 to 5.000 (fixed)											
	0-2.5V [2.5V]	22kΩ	0.000 to 2.500 (fixed)											
AC current	0-5A [5A]	0.01Ω	0.000 to 5.000 (fixed)											
	0-2.5A [2.5A]	0.01Ω	0.000 to 2.500 (fixed)											
	0-500mA [500mA]	0.1Ω	0.0 to 500.0 (fixed)											
	0-250mA [250mA]	0.1Ω	0.0 to 250.0 (fixed)											
	0-100mA [100mA]	0.5Ω	0.0 to 100.0 (fixed)											
	0-50mA [50mA]	0.5Ω	0.00 to 50.00 (fixed)											

## ■ Functions

### ◎ AC frequency measurement [PA1 group: d o t]

It measures input signal frequency when it is AC input. It uses fixed decimal point[PA1: d o t], measured range can be changed by setting and measured range of decimal point position is as below chart. It is available to adjust the upper gradient at [PA 1: i n b, H] and [PA 1: i n b, E]. In order to measure frequency normally, input signal, over 10% F.S. of the measured range, should be supplied. Please select the proper point of measurement terminal.

#### ① Measuring range

Decimal point position	0.000	0.00	0.0	0
Decimal point position	0.100 to 9.999Hz	0.10 to 99.99Hz	0.1 to 999.9Hz	1 to 9999Hz

※Accuracy of frequency measurement:

Below 1kHz, F.S. ±0.1rdg ±2digit.

From 1kHz to 10kHz, F.S. ±0.3rdg ±2digit.

#### ② i n b, H: 0.100 to 9.999

[Gradient adjustment of high value]

#### ③ i n b, E: 10<sup>-2</sup>, 10<sup>-1</sup>, 10<sup>0</sup>, 10<sup>1</sup>[Index adjustment of i n b, H]

### ◎ Zero adjustment

#### (Deviation correction function of low limit display value)

It adjusts the display value of the optional configured input value as zero by force, zero point error can be adjusted with 3 ways as below. When zero point adjustment with front key and Hold terminal is finished normally, zero point of measurement terminal is displayed and the adjusted value at saved in i n b, L automatically.

Operation	Input correction value	Front panel key	External input signal
Description	PA 1:Direct input correction value method at i n b, L	⏏, ⏏ keys are pressed for 3sec. at measuring mode.	Short-circuit External hold terminal 11, 12 over min. 50m. ※It is enable to use in option mode.

※Refer to "◎ Error correction function", "◎ Error display function" and "■ Parameter 2" for function and error.

### ◎ Current output (DC4-20mA) scale [PA 2 group: F5-H / F5-L]

It sets current output for the display value at the output current DC 4-20mA. It sets display value for 4mA at F5-L and 20mA at F5-H and the range between F5-H and F5-L should be 10% F.S. (When it sets as under 10% F.S., it changed as over 10% F.S. automatically.) Preset display value is fixed to output as 4mA at under F5-L and 20mA at over F5-H.

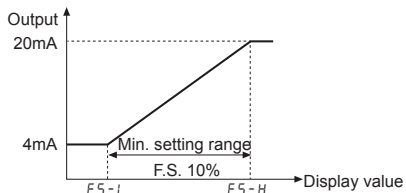

### ◎ Initialization

It initializes as the factory default status. If press ⏏, ⏏, ⏏ keys together for 2sec. in RUN mode, i n b, L mode and the setting value [n0] is displayed every 0.5 sec. and it will be initialized as the factory default when press MODE key after change n0 → 4E5.

ts are 'a' and 'b' and particular values are 'A' and 'B', it will display a=A, b=B as below graphs.

## ⊙ Error display

Display	Description
HHHH	Flashed when measured input is exceeded the max. allowable input (110%)
LLLL	Flashes when measured input is exceeded the min. allowable input (-10%)
d-HH	Flashes when display input is exceeded max. display range (9999)
d-LL	Flashes when display input is exceeded min. display range (-1999)
F-HH	Flashes when measuring frequency is exceeded the max. measuring rvalue (9999)
00Er	Flashes when it exceeds zero adjustment range ( $\pm 99$ )

- ⊗ Error display is released automatically when it is in the measured and display range.
- ⊗ "LLLL" is displayed when the measuring input is 4-20mA.
- ⊗ After flashing "00Er" 2 times when it exceeds the zero range, it returns to RUN mode.

## ⊙ Display scale

[PA 1 group: H-5C / L-5C]

This function is to display setting (-1999 to 9999) of particular High/Low-limit value in order to display High/Low-limit value of measured input. If measured inputs are 'a' and 'b' and particular values are 'A' and 'B', it will display a=A, b=B as below graphs.

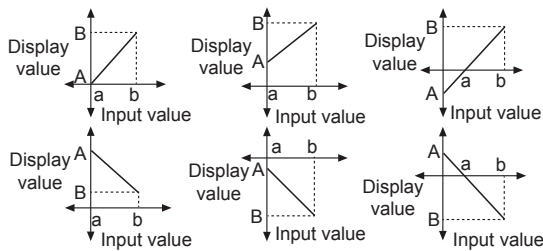

## ⊙ Gradient correction[PA1: I nbH]

It corrects the gradient of prescale value and display value. (Figure 1) Display value Y can be adjusted as  $\alpha$ ,  $\beta$  times against X input value by correction function [I nbH] and used as input function of max. display value [H-5C]. Adjustment range is 0.100 to 5.000 and multiply current gradient.

E.g.) To display "3.000" in DC 200mV input for measured input specification as 0 to 1V,

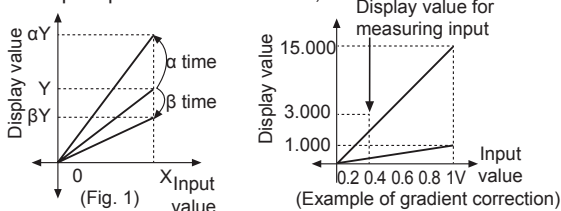

- Select 0-1VDC for measured input in Parameter 1.
- Standard specification in input: 0-1VDC and 1.000 therefore it has to be 15.000[H-5C] for 1VDC (Input) in order to display 3.000 for 200mVDC (input). But it is unable due to Set range is 9.999.
- In this case, please check below chart. Please set as  $I nbH \times H-5C = 15.000$ .

Setting	H-5C	L-5C	I nbH	Note
①	Disable	0.000	1.000	—
②	7.500	0.000	2.000	In this case, any setting methods display the same display value.
③	5.000	0.000	3.000	
④	3.750	0.000	4.000	
⑤	3.000	0.000	5.000	

## ⊙ Error correction[PA 1 group: I nbL / I nbL]

It corrects display value error of measured input.

I nbL:  $\pm 99$  (Adjust deviation of low value)

I nbH: 5.000 to 0.100 [Correct gradient (%) of high value]

Display value = (Measured value  $\times I nbH$ ) + I nbL  
E.g.) When the measured range is 0 to 500V, and the display range is 0 to 500.0. If the low display value is "1.2" to 0V input, set -12 as I nbL value to display "0.0" by adjusting offset of the low value. The display value to 500V measured input varies by adjusting the offset of low value. If this display value is "501.0", calculate  $500.0/501.0$  (desired display value/the display value), and set the 0.998 correction value as the I nbH to display 500.0 by adjusting gradient of high value.

⊗ The offset correction range of I nbL is within -99 to 99 for D<sup>0</sup>, D<sup>1</sup> digit regardless of dot.

## ⊙ Display cycle delay[PA 2 group: dI 5L]

In some applications the measured input may fluctuate which in turn causes the display to fluctuate. By adjusting the display cycle delay function time in the dI 5L mode in parameter 2, the operator can adjust the display time within a range of 0.1 sec to 5 sec. For example, if the operator sets the display cycle time to 4.0 sec., the display value displayed will be the average input value over 4 sec. and also will show any changes if any every 4 sec.

## ⊙ Monitoring peak display value

[PA 0 group: HPEL / LPEL]

It monitors max./min. value of display value based on the current displays value and then displays the data at HPEL, LPEL of parameter 0. Set the delay time (0 to 30 sec.) at PEL of parameter 2 in order to prevent malfunction caused by initial overcurrent or overvoltage, when monitoring the peak value. Delay time is 0 to 30 sec. and it starts to monitor the peak value after the set time. When pressing any one of  $\left[ \left[ \left[ \right] \right] \right]$  keys at HPEL, LPEL of parameter 0, the monitored data is initialized.

⊗ HPEL, LPEL parameters is not displayed when monitoring delay time [PEL] of parameter 2 group is set as 00 sec. [00 5].

(A) Photoelectric Sensors
(B) Fiber Optic Sensors
(C) Door/Area Sensors
(D) Proximity Sensors
(E) Pressure Sensors
(F) Rotary Encoders
(G) Connectors/ Sockets
(H) Temperature Controllers
(I) SSRs / Power Controllers
(J) Counters
(K) Timers
(L) Panel Meters
(M) Tacho / Speed / Pulse Meters
(N) Display Units
(O) Sensor Controllers
(P) Switching Mode Power Supplies
(Q) Stepper Motors & Drivers & Controllers
(R) Graphic/ Logic Panels
(S) Field Network Devices
(T) Software

# MT4N Series

## ◎ Preset output mode

[PA 2 group:  $\text{OUT.L}$  /  $\text{OUT.H}$ ]

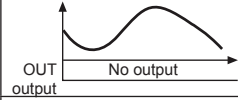
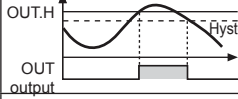
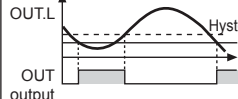
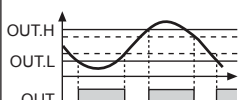
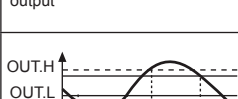
Mode	Output operation	Operation
OFF		No output
Hi		Period ON : Display value $\geq$ OUT.H Period OFF : Display value $\leq$ OUT.H-Hys
Lo		Period ON : Display value $\leq$ OUT.L Period OFF : Display value $\geq$ OUT.L+Hys
HL		Period ON : Display value $\leq$ OUT.L or Display value $\geq$ OUT.H Period OFF : Display value $\geq$ OUT.L+Hys or Display value $\leq$ OUT.H-Hys
HL-G		Period ON : OUT.L $\leq$ Display value $\leq$ OUT.H+Hys Period OFF : Display value $\leq$ OUT.L-Hys or Display value $\geq$ OUT.H+Hys

※Set output mode separately for each OUT1/OUT2.

※OUT1/OUT2 are operated individually depending on output operation mode.

※Setting value mode of parameter group 0 is displayed by output operation mode selection.

※GO is outputted within the period both OUT1/OUT2 are off. (NPN/PNP Open collector output type.)

## ■ Communication Output

(Refer to pages L-46 to L-47.)