

MP5S/MP5Y/MP5W/MP5M Series

High-Performance, Digital Pulse Meter

■ Features

- 13 kinds of various operation modes:
Revolution, speed, frequency, absolute ratio, passing time, error ratio, cycle, density, passing speed, error, time width, length measurement, time difference, interval, multiplication (MP5M Series have 11 operation modes)
- Various output function:
Relay output, NPN/PNP open collector output, low speed serial output, BCD output, PV transmission, RS485 communication output
- Various functions:
Prescale function, data monitoring function, hysteresis function, peak value monitoring function, monitoring delay function, auto zero time setting function, lock setting function, display period delay function
- Max. display range: -19999 to 99999 (MP5M: 0 to 99999)
- Various display units: rpm, rps, Hz, kHz, sec, min, m, mm, mm/s, m/s, m/min, m/h, *l/s*, *l/min*, *l/h*, %, counts, etc.
- Selectable voltage input (PNP) or no voltage input (NPN)
- 50kHz high speed response



⚠ Please read "Caution for your safety" in operation manual before using.



■ Ordering Information

MP 5 S - 4 N

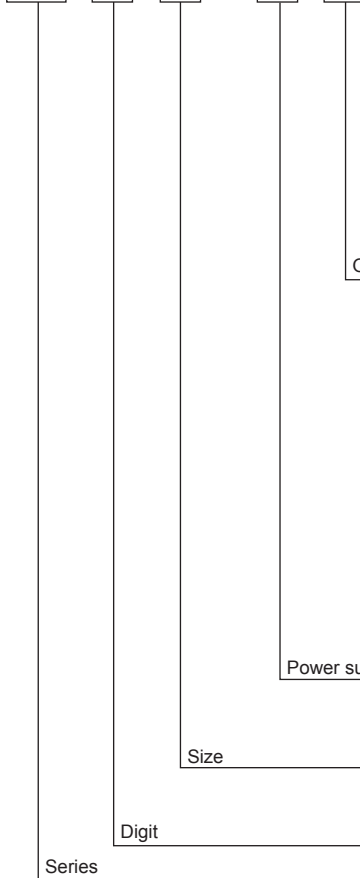



		Main output (Comparative value output)	Sub output (Display value output)
S Type	N	Indicator	—
	Y Type	N	Indicator
Y Type	1	NPN open collector quintuple output	—
	2	PNP open collector quintuple output	—
	3	Indicator	BCD Dynamic
	4	Indicator	PV transmission output (DC4-20mA)
	5	Indicator	RS485 communication output
W Type	N	Indicator	—
	A	Five relay (HH, H, GO, L, LL)	—
	1	Triple relay (H, GO, L)	—
	2	NPN open collector quintuple output	BCD dynamic
	3	PNP open collector quintuple output	BCD dynamic
	4	NPN open collector quintuple output	PV transmission output (DC4-20mA)
	5	PNP open collector quintuple output	PV transmission output (DC4-20mA)
	6	NPN open collector quintuple output	Low speed serial output
	7	PNP open collector quintuple output	Low speed serial output
	8	NPN open collector quintuple output	RS485 communication output
M Type	9	PNP open collector quintuple output	RS485 communication output
	N	Indicator	—
	1	Relay single (High-limit) output + NPN open collector output	—
	2	Relay dual (High/Low-limit) output + NPN open collector output	—
	2	24VDC (Only for MP5Y-24)	
	4	100-240VAC 50/60Hz	
	S	DIN W48×H48mm	
	Y	DIN W72×H36mm	
	W	DIN W96×H48mm	
	M	DIN W72×H72mm	
	5	99999 (5digit)	
	MP	Pulse meter	

※PNP open collector output: Option

Pulse(Rate) Meter

■ Specifications (MP5S/MP5Y/MP5W Series)

Series	MP5S-4N	MP5Y-24	MP5Y-4□	MP5W-4□
Display method	7 Segment LED display (Zero blanking type)			
Character size	W4 × H8mm	W6.8 × H13.8mm		
Max. indication	-19999 to 99999			
Power supply	100-240VAC 50/60Hz	24VDC	100-240VAC 50/60Hz	100-240VAC 50/60Hz
Allowable operation voltage	90 to 110%			
Power consumption	Max. 7.5VA	Max. 6W	Max. 7VA	Max. 6VA
Power for external sensor	12VDC ±10%, 80mA			
Input frequency	<ul style="list-style-type: none"> • Soild-state input: Max. 50kHz (Pulse width: Each over 10μs) • Contact input: Max. 45Hz (Pulse width: Over 11ms) 			
Input level	[Voltage input] High: 4.5-24VDC, Low: 0-1.0VDC, Input impedance: 4.5kΩ [No-voltage input] Impedance at short-circuit: Max. 300Ω, Residual voltage: Max. 1V Impedance at open-circuit: Min. 100kΩ			
Measuring range	<ul style="list-style-type: none"> • Mode F1, F2, F7, F8, F9, F10: 0.0005Hz to 50kHz • Mode F3: 0.02s to 3,200s • Mode F4, F5, F6: 0.01s to 3,200s • Mode F11, F12, F13: 0 to 4 × 10⁹ Count 			
Measuring accuracy (23 ±5°C)	<ul style="list-style-type: none"> • Mode F1, F2, F7, F8, F9, F10: F.S. ±0.05% rdg ±1digit • Mode F3, F4, F5, F6: F.S. ±0.01% rdg ±1digit 			
Display period	0.05 / 0.5 / 1 / 2 / 4 / 8sec. (It is same with period of output update.)			
Operation mode	Number of revolution/Speed/Frequency (F1), Passing speed (F2), Cycle (F3), Passing time (F4), Time width (F5), Time defference (F6), Absolute ratio (F7), Error ratio (F8), Density (F9), Error (F10), Length measurement (F11), Interval (F12), Multiplication (F13) ※Refer to the M-20 to 23 for the operation mode.			
Prescale function	Direct input method (0.0001×10 ⁻⁹ to 9.9999×10 ⁹)			
Hysteresis ^{※1}	0 to 9999			
Other functions	<ul style="list-style-type: none"> • Lock setting function • Auto-Zero time setting function • Time unit selection function • Peak value monitoring function • Memory protection function (Mode F13 applied only) • Lock setting function • Monitoring delay function • Auto-zero time setting function • Current output range selection (Current output type only) • Comparative output function (HH, H, GO, L, LL) • Time unit selection function • Deviation memory function (F output mode applied only) • Peak value monitoring function • Remote/Local switching function (Communication output type only) • Data bank switching function^{※2} • Memory protection function (Mode F13 applied only) 			
Main output	Triple relay	—	—	250VAC 3A resistive load
	Quintuple relay			
	NPN Open collector (Quintuple)			
	PNP Open collector (Quintuple)			
Sub output	BCD Dynamic	—	NPN Open collector 12-24VDC 30mA Max.	NPN Open collector 12-24VDC 20mA max.
	Low speed serial output	—	—	—
	PV transmission	—	DC4-20mA Load 600Ω Max. (Response time: Max. 800ms)	DC4-20mA Load 600Ω Max.
	RS485 communication	—	—	31 channels, Mutual direction communication function
Memory protection	Non-volatile memory (Input: Min. 100,000 times)			
Insulation resistance	Min. 100MΩ (at 500VDC megger) Between charge part and non-charge part			
Dielectric strength	2000VAC 60Hz 1minute (Between terminals of AC power and case, Between terminals of AC power and measuring input terminals)			
Impulse noise strength	±2000V R-phase, S-phase the square wave noise (pulse width: 1μs) by the noise simulator, repeat frequency 60Hz			
Vibration	Mechanical	0.75mm amplitude at frequency of 10 to 55Hz (for 1 min.) in each X, Y, Z direction for 2 hours		
	Malfuction	0.5mm amplitude at frequency of 10 to 55Hz (for 1 min.) in each X, Y, Z direction for 10 min.		
Shock	Mechanical	300m/s ² (approx. 30G) in each X, Y, Z direction for 3 times		
	Malfuction	100m/s ² (approx. 10G) in each X, Y, Z direction for 3 times		
Relay life cycle	Malfuction	—	Min. 10,000,000 operations	
	Mechanical	—	Min. 100,000 operations (250VAC 3A load current)	
Environ-ment	Ambient temperature	-10 to 50°C, storage: -20 to 60°C		
	Ambient humidity	35 to 85%RH, storage: 35 to 85%RH		
Weight ^{※3}	Approx. 199.5g (approx. 141.5g)	Approx. 209g (approx. 117g)		Approx. 301.5g (approx. 177g)
Approval	CE  us		—	CE  us

※1: The hysteresis setting range is changed by the setting position of decimal point. (Refer to M-26 for hysteresis function.)

※2: Data bank switching function is in MP5W Series only.

※3: The weight includes packaging. The weight in parentheses is for unit only.

(A) Photoelectric Sensors
(B) Fiber Optic Sensors
(C) Door/Area Sensors
(D) Proximity Sensors
(E) Pressure Sensors
(F) Rotary Encoders
(G) Connectors/ Sockets
(H) Temperature Controllers
(I) SSRs / Power Controllers
(J) Counters
(K) Timers
(L) Panel Meters
(M) Tacho / Speed / Pulse Meters
(N) Display Units
(O) Sensor Controllers
(P) Switching Mode Power Supplies
(Q) Stepper Motors & Drivers & Controllers
(R) Graphic/ Logic Panels
(S) Field Network Devices
(T) Software

MP5S/MP5Y/MP5W/MP5M Series

Specifications (MP5M Series)

Model	MP5M-4N	MP5M-41	MP5M-42
Indicator		High-limit setting type	High/Low-limit setting type
Display method	7 Segment LED display (Zero blanking), Character size: W4 X H8mm		
Max. indication	0.0001 to 99999		
Power supply	100-240VAC 50/60Hz		
Allowable operation voltage	90 to 110%		
Power consumption	Approx. 7.5VA (240VAC)	Approx. 8VA (240VAC)	
Power for external sensor	12VDC $\pm 10\%$, 80mA		
Input frequency	<ul style="list-style-type: none"> Solid-state input: Max. 50kHz (pulse width: over 10μs) Contact input: Max. 45Hz (pulse width: over 11ms) 		
Input level	[Voltage input] High: 4.5-24VDC, Low: 0-1.0VDC, Input impedance: 4.5k Ω [No-voltage input] Impedance at short-circuit: Max. 300 Ω , Residual voltage: Max. 1V Impedance at open-circuit: Min. 100k Ω		
Measuring range	<ul style="list-style-type: none"> Mode F1, F2, F7, F8: 0.0005Hz to 50kHz Mode F4, F5, F6: 0.01s to 3,200s 	<ul style="list-style-type: none"> Mode F3: 0.02s to 3,200s Mode F9, F10, F11: 0 to 4 $\times 10^9$ Count 	
Measuring accuracy (23 $\pm 5^\circ$ C)	<ul style="list-style-type: none"> Mode F1, F2, F7, F8: F.S. $\pm 0.05\%$ rdg ± 1digit Mode F3, F4, F5, F6: F.S. $\pm 0.01\%$ rdg ± 1digit 		
Display period	0.05 / 0.5 / 1 / 2 / 4 / 8sec. (It is same with period of output update.)		
Operation mode	Number of revolution/Speed/Frequency (F1), Passing speed (F2), Cycle (F3), Passing time (F4), Time width (F5), Time difference (F6), Absolute ratio (F7), Density (F8), Length measurement (F9), Interval (F10), Multiplication (F11) <small>※Refer to M-20 to 23 for operation mode.</small>		
Prescale function	Direct input method (0.0001 $\times 10^{-9}$ to 9.9999 $\times 10^9$)		
Hysteresis	—	0 to 9999	
Other function	<ul style="list-style-type: none"> Lock setting function Auto-Zero time setting function Time unit selection function Peak value monitoring function Memory protection function (Mode F11 applied only) 	<ul style="list-style-type: none"> Lock setting function Monitoring delay function Auto-Zero time setting function Time unit selection function Peak value monitoring function Memory protection function (Mode F11 applied only) High-limit output function (H) 	<ul style="list-style-type: none"> Lock setting function Monitoring delay function Auto-Zero time setting function Time unit selection function Peak value monitoring function Memory protection function (Mode F11 applied only) Comparative output function (H, L) Output mode selection function (S, H, L, B, I, F) Deviation memory function (F output mode applied only)
Main output	Relay NPN Open Collector	250VAC 3A resistive load 1c 30VDC 100mA Max.	250VAC 3A resistive load 1a \times 2 30VDC 100mA Max. \times 2
Memory protection	Non-volatile memory (Input: Min. 100,000 operations)		
Approval			
Unit weight	Approx. 275g	Approx. 310g	Approx. 330g

※MP5S, MP5Y, MP5W have same function.

※Environment resistance is rated at no freezing or condensation.

Connections

MP5M Series

MP5M-4N (Indicator)

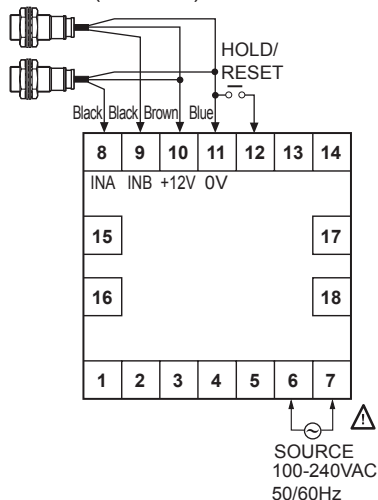

MP5M-41 (High-limit setting type)

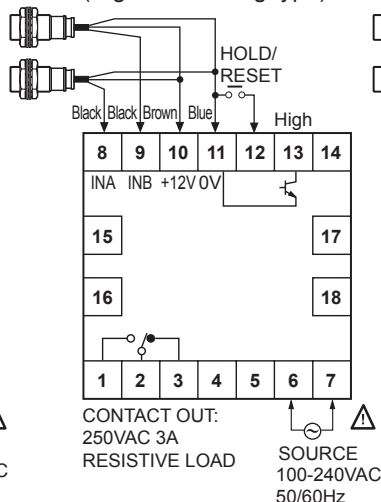

MP5M-42 (High/Low-limit setting type)

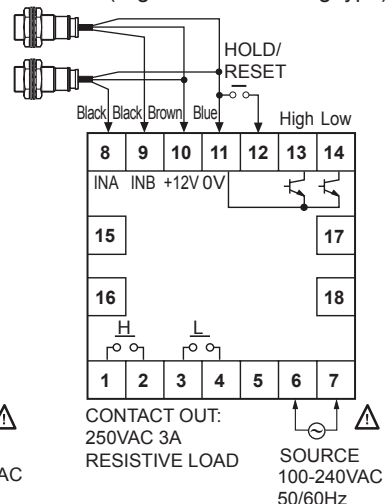

Pulse(Rate) Meter

■ Connections

◎ MP5S Series

● MP5S-4N (Indicator)

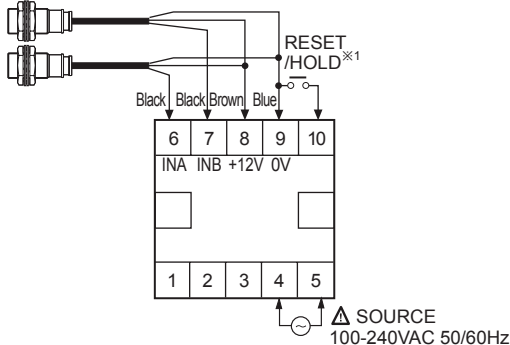

※1: It is used for RESET terminal when an operation mode is F13. (Refer to the M-20 to 23 for operation mode.)

◎ MP5Y Series

● MP5Y-□N (Indicator)

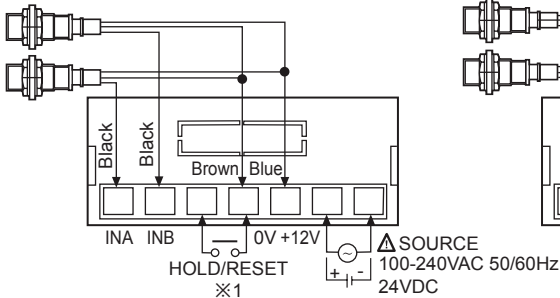

● MP5Y-□4 to □5 (Main/Sub output type)

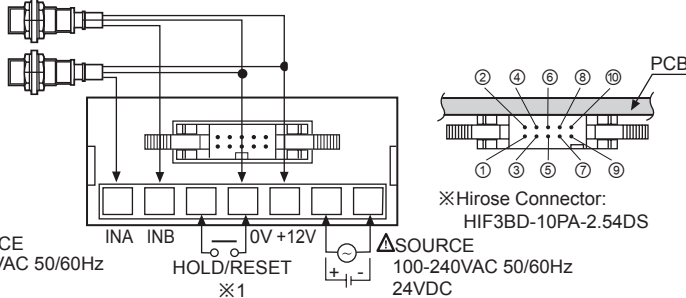

※1: It is used for RESET terminal when an operation mode is F13. (Refer to M-20 to 23 for operation mode.)

● Main output (Connector)

● MP5Y-□1 (NPN open collector output)

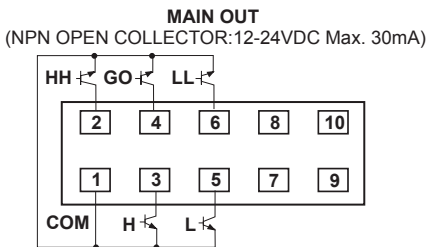

● MP5Y-□2 (PNP open collector output)

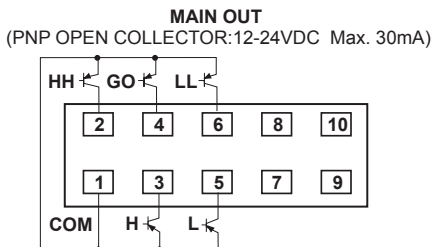

● Sub output (Connector)

● MP5Y-□3 (BCD dynamic output)

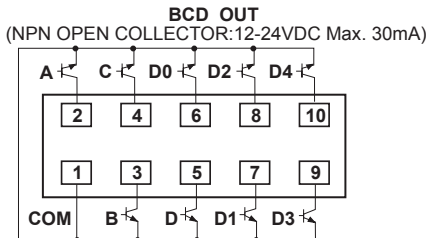

● MP5Y-□4 (PV transmission output)

DC4-20mA
Load 600Ω Max.

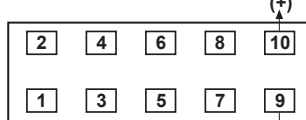

● MP5Y-□5 (RS485 communication output)

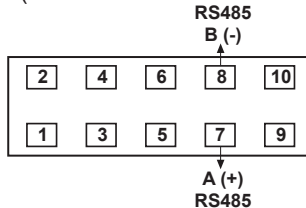

※Main output type & sub output type: Customizable

(A)	Photoelectric Sensors
(B)	Fiber Optic Sensors
(C)	Door/Area Sensors
(D)	Proximity Sensors
(E)	Pressure Sensors
(F)	Rotary Encoders
(G)	Connectors/ Sockets
(H)	Temperature Controllers
(I)	SSRs / Power Controllers
(J)	Counters
(K)	Timers
(L)	Panel Meters
(M)	Tacho / Speed / Pulse Meters
(N)	Display Units
(O)	Sensor Controllers
(P)	Switching Mode Power Supplies
(Q)	Stepper Motors & Drivers & Controllers
(R)	Graphic/ Logic Panels
(S)	Field Network Devices
(T)	Software

MP5S/MP5Y/MP5W/MP5M Series

◎ MP5W Series

● MP5W-□N (Indicator)

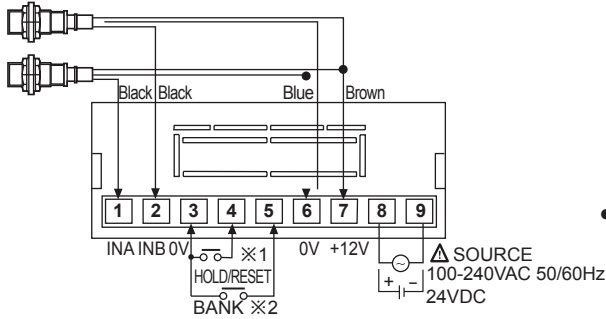

- *1: It is used for RESET terminal when an operation mode is F13. (Refer to the M-20 to 23)
- *2: Refer to M-26 for BANK function.
- *Main output type & sub output type: option

● MP5W-□A (Five relay output)

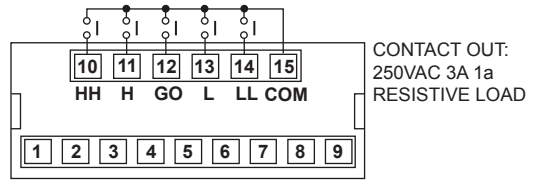

● MP5W-□1 (Triple relay output)

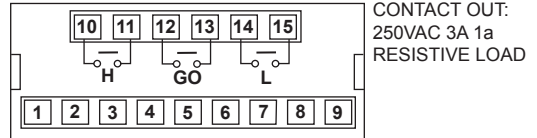

● Main output+Sub output (Connector)

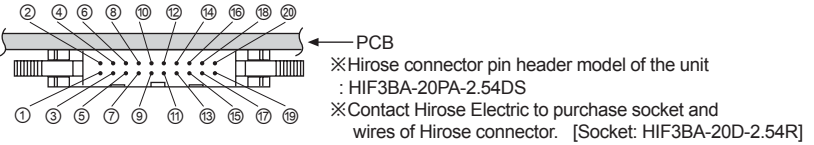
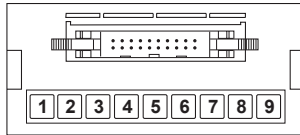

● MP5W-□2/ MP5W-□3 (NPN/PNP open collector output + BCD output)

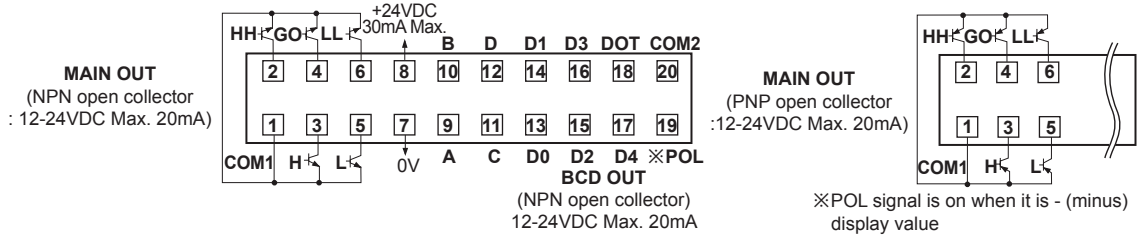

● MP5W-□4/ MP5W-□5 (NPN/PNP open collector output + PV transmission output (DC4-20mA) output)

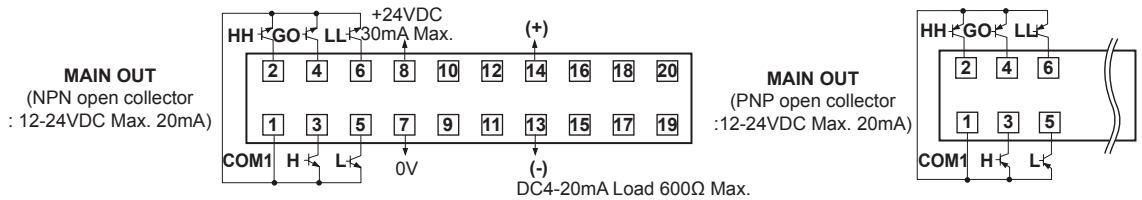

● MP5W-□6/ MP5W-□7 (NPN/PNP open collector output + Low speed serial output)

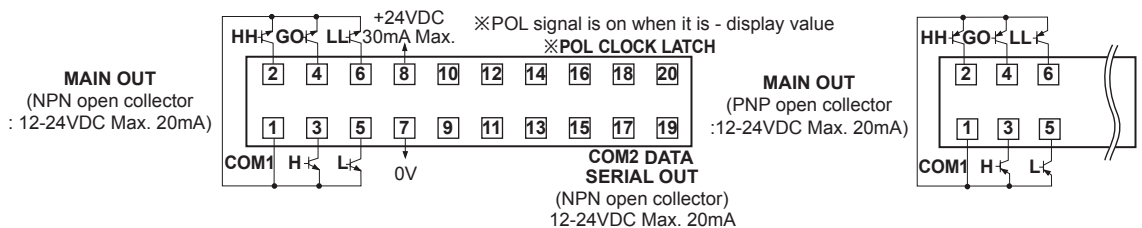

● MP5W-□8/ MP5W-□9 (NPN/PNP open collector output + RS485 communication output)

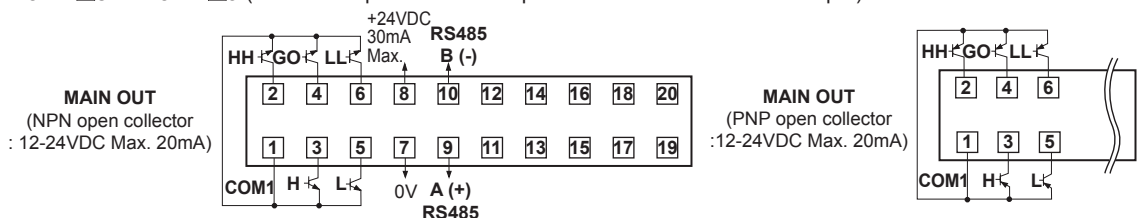

Pulse(Rate) Meter

Dimensions

(unit: mm)

- MP5S Series
- Bracket

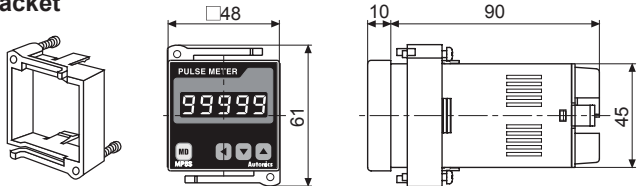

● Panel cut-out

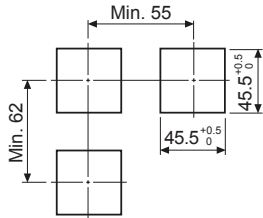

- MP5Y Series

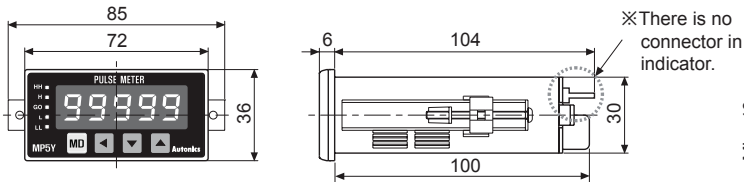

● Panel cut-out

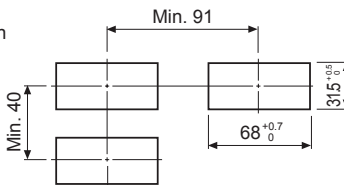

※Hirose connector: HIF3BD-10PA-2.54DS

- MP5W Series

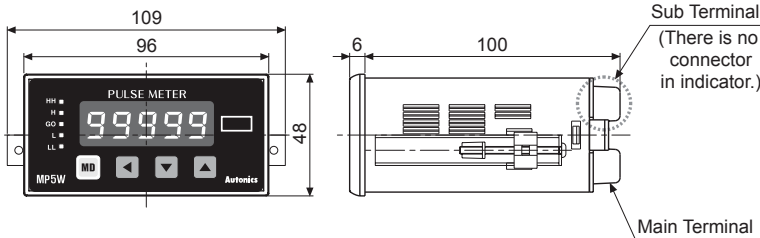

● Panel cut-out

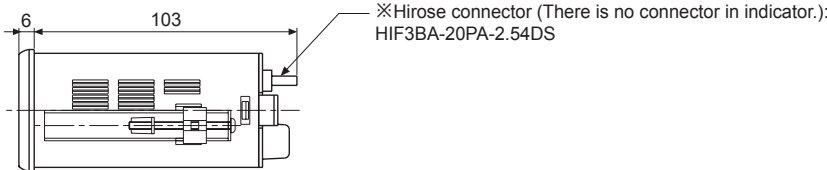
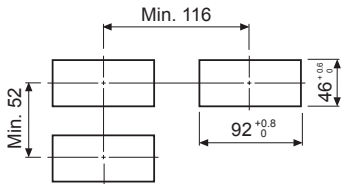

- MP5M Series

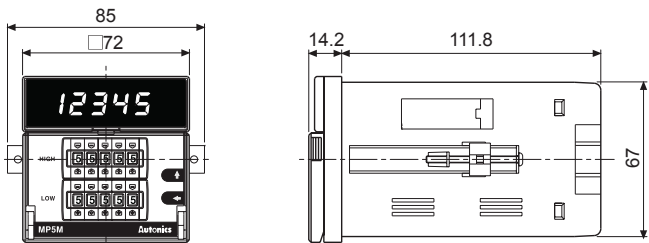

● Panel cut-out

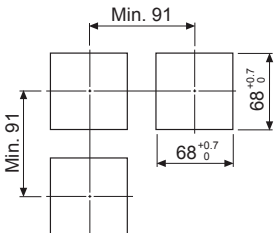

- (A) Photoelectric Sensors
- (B) Fiber Optic Sensors
- (C) Door/Area Sensors
- (D) Proximity Sensors
- (E) Pressure Sensors
- (F) Rotary Encoders
- (G) Connectors/ Sockets
- (H) Temperature Controllers
- (I) SSRs / Power Controllers
- (J) Counters
- (K) Timers
- (L) Panel Meters
- (M) Tacho / Speed / Pulse Meters
- (N) Display Units
- (O) Sensor Controllers
- (P) Switching Mode Power Supplies
- (Q) Stepper Motors & Drivers & Controllers
- (R) Graphic/ Logic Panels
- (S) Field Network Devices
- (T) Software

MP5S/MP5Y/MP5W/MP5M Series

Input Specifications

Input signal

Solid-state input

- Input frequency: **50kHz Max.**
Standard duty ratio of input signal is 1:1,
ON/OFF pulse width should be over 10 μ s.
- Input voltage level: High \rightarrow 4.5-24VDC, Low \rightarrow 0-1.0VDC

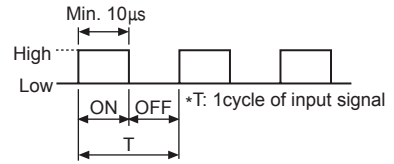

Relay contact input

- Input frequency: **45Hz Max.**
ON/OFF pulse width should be over 11ms.
- Relay contact specification: Please use a relay contact that can carry the load current (Min. 12VDC 2mA).

Input type

MP5 has NPN input and PNP input and it is able to select in Parameter group 1.

When it is NPN input type

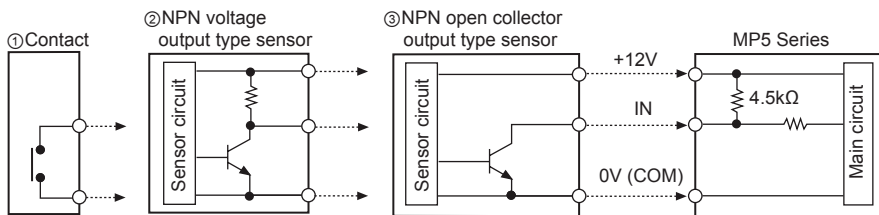

When it is PNP input type

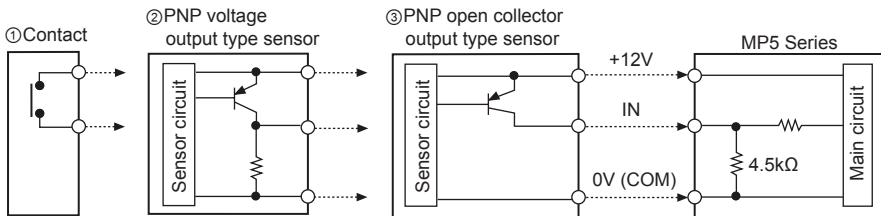

※O-C is Open Collector output.

Output Specifications (MP5Y/ MP5W Series)

Transistor output

- Output: Comparative output or alarm output (Refer to M-24 page "Output mode")
- Output type: NPN open collector
- Rated load voltage: 12-24VDC
- Max. load current: 30mA

BCD dynamic output (Negative logic)

- Output: Display value
- Output signal:
BCD Data (A, B, C, D, DOT) \leftarrow A: Lowest bit
Dot: Highest bit
Digit Data (D0, D1, D2, D3, D4) \leftarrow D0: Lowest digit
D4: Highest digit

※There is no DOT data output in MP5Y-□3, therefore decimal point should be mark in first display plate.

- Output type: NPN open collector
- Rated load voltage: 12-24VDC
- Max. load current: 30mA (MP5Y)/ 20mA (MP5W)

Ex)When BCD dynamic output is 125.89

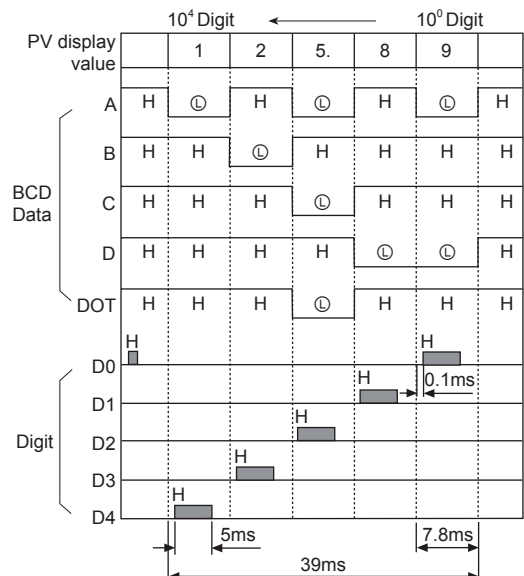

◎ Low speed serial output (Negative logic)

- Output: Display value
- Output signal: Clock, Data, Latch
- Clock cycle: 50Hz
- Output CLK bit: 25 bit
- Output Data bit: 25 bit
- Output form: NPN open collector
- Rated load voltage: 12-24VDC
- Max. load current: 30mA (MP5Y)/ 20mA (MP5W)

• Serial transmission time diagram

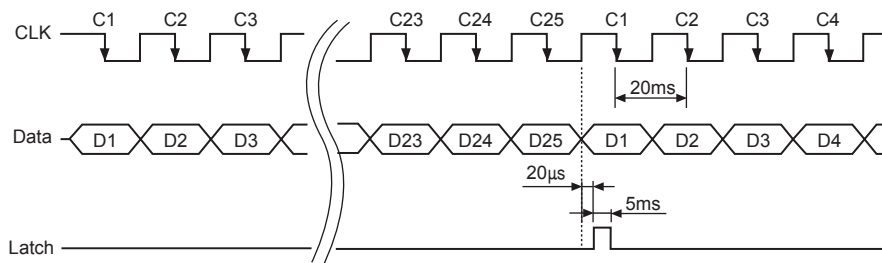

• Data output order when it is serial transmission

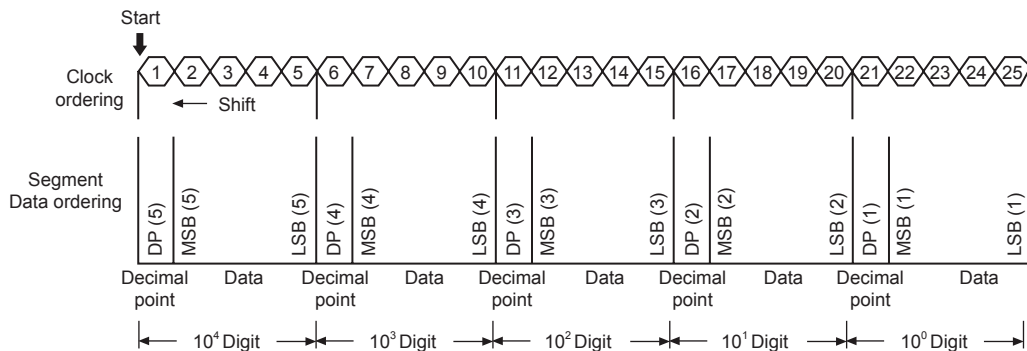

◎ PV transmission output (DC4-20mA)

- Application: Transmit the measured value
- Function: This function is to transmit DC4-20mA converted from measured display value between High limit output[F5-H] and Low limit[F5-L].
- Range of High/Low limit output setting
 - High limit setting range[F5-H]
 - From min. to max within range of measurement
 - Low limit setting range[F5-L]
 - From min. to max within range of measurement
 - (F5-H \geq F5-L + 1 digit)
- Load resistance: Max. 600Ω
- Resolution: 8000-division

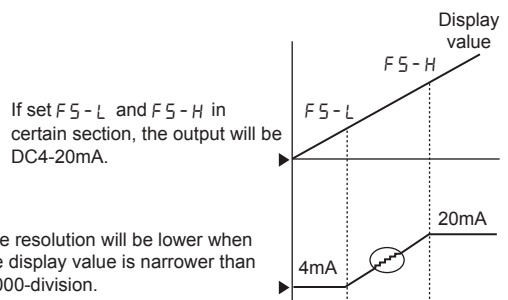

◎ RS485 communication output

- Address: 0 to 99 address
- Transmission speed (Baud rate): 2400/4800/9600 bps
- Transmission code: ASCII
- Parity Bit: No
- Data Bit: 8 Bit
- Stop Bit: 1 Bit
- Communication items
 - MP5W ← PC: Comparative value of each bank data, prescale value and peak value, RESET control
 - MP5W → PC: Comparative value of each bank data, prescale value and peak value, display value
- ※ Refer to the M-26 for communication data.

(A) Photoelectric Sensors

(B) Fiber Optic Sensors

(C) Door/Area Sensors

(D) Proximity Sensors

(E) Pressure Sensors

(F) Rotary Encoders

(G) Connectors/ Sockets

(H) Temperature Controllers

(I) SSRs / Power Controllers

(J) Counters

(K) Timers

(L) Panel Meters

(M) Tacho / Speed / Pulse Meters

(N) Display Units

(O) Sensor Controllers

(P) Switching Mode Power Supplies

(Q) Stepper Motors & Drivers & Controllers

(R) Graphic/ Logic Panels

(S) Field Network Devices

(T) Software

MP5S/MP5Y/MP5W/MP5M Series

Parameter Group Chart For Model

- The parameter has different mode according to each model, therefore refer to "Parameter group chart of operation mode" and "Parameter".
- ○: When selecting the operation mode, the parameter will be displayed.
- ×: When selecting the operation mode, the parameter will not be displayed.

Parameter	Model	MP5S-4N MP5Y-4N MP5W-4N MP5M-4N	MP5Y-41 MP5Y-42	MP5Y-43	MP5Y-44	MP5Y-45	MP5W-41	MP5W-4A MP5W-42 MP5W-43	MP5W-44 MP5W-45	MP5W-46 MP5W-47	MP5W-48 MP5W-49	MP5M-41	MP5M-42
	Parameter group 0	<i>PSt.hh</i>	×	○	×	×	×	×	○	○	○	○	×
	<i>PSt.h</i>	×	○	×	×	×	○	○	○	○	○	×	×
	<i>PSt.L</i>	×	○	×	×	×	○	○	○	○	○	×	×
	<i>PSt.LL</i>	×	○	×	×	×	×	○	○	○	○	×	×
	<i>hPEL</i>	○	○	○	○	○	○	○	○	○	○	○	○
	<i>LPEL</i>	○	○	○	○	○	○	○	○	○	○	○	○
Parameter group 1	<i>nodE</i>	○	○	○	○	○	○	○	○	○	○	○	○
	<i>in-A</i>	○	○	○	○	○	○	○	○	○	○	○	○
	<i>in-b</i>	○	○	○	○	○	○	○	○	○	○	○	○
	<i>out-t</i>	×	○	×	×	×	○	○	○	○	○	×	○
	<i>hYS</i>	×	○	×	×	×	○	○	○	○	○	○	○
	<i>GuAr.d ↔ F.dEFY</i>	×	○	×	×	×	○	○	○	○	○	×	○
	<i>GuAr.d ↔ StAr.t</i>	×	○	×	×	×	○	○	○	○	○	×	○
	<i>RUt.oA</i>	○	○	○	○	○	○	○	○	○	○	○	○
	<i>RUt.oB</i>	○	○	○	○	○	○	○	○	○	○	○	○
	<i>nEno</i>	○	○	○	○	○	○	○	○	○	○	○	○
Parameter group 2	<i>P.bANy</i>	○	×	×	×	×	○	○	○	○	○	×	×
	<i>dot</i>	○	○	○	○	○	○	○	○	○	○	○	○
	<i>t.unT</i>	○	○	○	○	○	○	○	○	○	○	○	○
	<i>PSt.hh</i>	×	○	×	×	×	×	○	○	○	○	×	×
	<i>PSt.h</i>	×	○	×	×	×	○	○	○	○	○	×	×
	<i>PSt.L</i>	×	○	×	×	×	○	○	○	○	○	×	×
	<i>PSt.LL</i>	×	○	×	×	×	×	○	○	○	○	×	×
	<i>PSC.AH</i>	○	○	○	○	○	○	○	○	○	○	○	○
	<i>PSC.AY</i>	○	○	○	○	○	○	○	○	○	○	○	○
	<i>PSC.bH</i>	○	○	○	○	○	○	○	○	○	○	○	○
	<i>PSC.bY</i>	○	○	○	○	○	○	○	○	○	○	○	○
	<i>diSP.t</i>	○	○	○	○	○	○	○	○	○	○	○	○
Parameter group 3	<i>FS-h</i>	×	×	×	○	×	×	×	○	×	×	×	×
	<i>FS-L</i>	×	×	×	○	×	×	×	○	×	×	×	×
	<i>Addr</i>	×	×	×	×	○	×	×	×	×	○	×	×
	<i>bPS</i>	×	×	×	×	○	×	×	×	×	○	×	×
	<i>rEno.t</i>	×	×	×	×	○	×	×	×	×	○	×	×
	<i>LoC</i>	○	○	○	○	○	○	○	○	○	○	○	○

※ : Data bank (*P.bANy*) setting is available in only MP5W-□N.

Monitoring Delay Operation Function Chart By Each Output Mode

<i>out-t</i>	<i>StAr.d</i>	<i>out-h</i>	<i>out-L</i>	<i>out-b</i>	<i>out-l</i>	<i>out-F</i>
Comparative output limit function	○	×	×	○	×	○
Starting correction timer function	○	○	○	○	○	○

Pulse(Rate) Meter

Parameter Group Chart For Operation Mode

- Parameter display are different according to each operation mode, refer to "Parameter" part.
- "○": When select the operation mode, the parameter will be displayed.
- "x": When select the operation mode, the parameter will not be displayed.
- "◎": It is only able to set nPn,hF or Pn,hF for $i n-b$ sensor type in F11, F12, F13 of operation mode.

Parameter display		F1	F2	F3	F4	F5	F6	F7	F8	F9	F10	F11	F12	F13
Parameter group 0	<i>PSt.hh</i>	○	○	○	○	○	○	○	○	○	○	○	○	○
	<i>PSt.h</i>	○	○	○	○	○	○	○	○	○	○	○	○	○
	<i>PSt.L</i>	○	○	○	○	○	○	○	○	○	○	○	○	○
	<i>PSt.LL</i>	○	○	○	○	○	○	○	○	○	○	○	○	○
	<i>hPEL</i>	○	○	○	○	○	○	○	○	○	○	○	○	x
	<i>LPEL</i>	○	○	○	○	○	○	○	○	○	○	○	○	x
Parameter group 1	<i>nodE</i>	○	○	○	○	○	○	○	○	○	○	○	○	○
	<i>in-A</i>	○	○	○	○	○	○	○	○	○	○	○	○	○
	<i>in-b</i>	x	○	x	x	x	○	○	○	○	○	◎	◎	◎
	<i>out-t</i>	○	○	○	○	○	○	○	○	○	○	○	○	x
	<i>hYS</i>	○	x	x	x	x	x	○	○	○	○	x	x	x
	<i>GuAr.d ↔ F.dEFY</i>	○	○	○	○	○	○	○	○	○	○	○	○	x
	<i>GuAr.d ↔ StAr.t</i>	○	○	○	○	○	○	○	○	○	○	○	○	x
	<i>AUt.oA</i>	○	x	x	○	x	x	○	○	○	○	x	x	x
	<i>AUt.oB</i>	x	x	x	x	x	x	○	○	○	○	x	x	x
<i>nEno</i>	x	x	x	x	x	x	x	x	x	x	x	x	○	
Parameter group 2	<i>P.bAnL</i>	○	○	○	○	○	○	○	○	○	○	○	○	○
	<i>dot</i>	○	○	x	x	x	x	○	○	○	○	○	○	○
	<i>t.unL</i>	x	x	○	○	○	○	x	x	x	x	x	x	x
	<i>PSt.hh</i>	○	○	○	○	○	○	○	○	○	○	○	○	○
	<i>PSt.h</i>	○	○	○	○	○	○	○	○	○	○	○	○	○
	<i>PSt.L</i>	○	○	○	○	○	○	○	○	○	○	○	○	○
	<i>PSt.LL</i>	○	○	○	○	○	○	○	○	○	○	○	○	○
	<i>PSC.AH</i>	○	○	x	○	x	x	○	○	○	○	○	○	○
	<i>PSC.AY</i>	○	○	x	○	x	x	○	○	○	○	○	○	○
	<i>PSC.bH</i>	x	x	x	x	x	x	○	○	○	○	x	x	x
	<i>PSC.bY</i>	x	x	x	x	x	x	○	○	○	○	x	x	x
	<i>dI SP.t</i>	○	x	x	x	x	x	○	○	○	○	x	x	x
Parameter group 3	<i>FS-h</i>	When it is PV transmission output, it operates in all mode.												
	<i>FS-L</i>	When it is PV transmission output, it operates in all mode.												
	<i>Addr</i>	When it is RS485 communication output, it operates in all mode.												
	<i>bPS</i>	When it is RS485 communication output, it operates in all mode.												
	<i>rEnoE</i>	○	○	○	○	○	○	○	○	○	○	○	○	○

- (A) Photoelectric Sensors
- (B) Fiber Optic Sensors
- (C) Door/Area Sensors
- (D) Proximity Sensors
- (E) Pressure Sensors
- (F) Rotary Encoders
- (G) Connectors/ Sockets
- (H) Temperature Controllers
- (I) SSRs / Power Controllers
- (J) Counters
- (K) Timers
- (L) Panel Meters
- (M) Tacho / Speed / Pulse Meters
- (N) Display Units
- (O) Sensor Controllers
- (P) Switching Mode Power Supplies
- (Q) Stepper Motors & Drivers & Controllers
- (R) Graphic/ Logic Panels
- (S) Field Network Devices
- (T) Software

Operation Mode By Each Series

Operation mode	Frequency rotation speed	Passing speed	Cycle	Passing time	Time width	Time difference	Absolute ratio	Error ratio	Density	Error	Length measurement	Interval	Multiplication
MP5S, MP5Y, MP5W	F1	F2	F3	F4	F5	F6	F7	F8	F9	F10	F11	F12	F13
MP5M	F1	F2	F3	F4	F5	F6	F7	x	F8	x	F9	F10	F11