

# PMC-1HS/PMC-2HS Series

## 1-2-Axis High Speed Programmable Motion Controller

### ■ Features

- Max. 4Mpps high-speed operation
- 4 operation modes: Scan, Continuous, Index, Program
- 12 control command and 64 steps of operations
- Parallel I/O terminal built in which is connectable on PLC
- Operation program by exclusive switch, making and editing parameter
- Easy to operation of X, Y stage with joy stick
- RS232C port for all types
- Teaching and monitoring function by using teaching unit (PMC-2TU-232)



PMC-1HS (USB)    PMC-1HS (232)    PMC-2HS (USB)    PMC-2HS (232)

**⚠ Please read "Caution for your safety" in operation manual before using.**



PMC-2TU-232

### ■ Ordering Information

PMC - 2HS - USB

Communication type	232	RS232C
	USB	USB / RS232C
Axis/Type	1HS	1-Axis high speed stand-alone
	2HS	2-Axis high speed stand-alone
Item	PMC	Programmable Motion Controller

※ Visit our web site ([www.autonics.com](http://www.autonics.com)) to download user manual and software [MotionStudio].

### ■ Specifications

Model	PMC-1HS-232	PMC-1HS-USB	PMC-2HS-232	PMC-2HS-USB
Control axis	1-Axis		2-Axis (each axis can be independently programmed)	
Motor for control	Pulse string input stepper motor or servo motor			
Power supply	24VDC ±10%			
Power consumption	Max. 6W			
Operation mode	Scan / Continuous / Index / Program			
Positioning type	Absolute position / Incremental position			
Index step numbers	64 indexes per each axis			
Positioning range	-8,388,608 to 8,388,607 (Available pulse scaling function)			
Drive speed numbers	4EA			
Drive speed	1 pps to 4 Mpps (1 to 8,000 × Magnification 1 to 500)			
Output pulse type	2 Pulse output (Line driver)			
Home search mode	High speed near home search (Step1) → Low speed home search (Step2) → Low speed encoder Z-phase search (Step3) → High speed offset movement (Step4) Configuring the detection method and Enable/Disable in each step.			
Program function	Memory	EEPROM		
	Step	64 Steps		
	Control	ABS, INC, HOM, IJP, OUT, OTP, JMP, REP, RPE, END, TIM, NOP (12 EA)		
	Start	Power ON program auto-start function		
	Home search	Power ON home search auto-start function		

# 1-2-Axis High Speed Programmable Motion Controller

## Specifications

Model	PMC-1HS-232	PMC-1HS-USB	PMC-2HS-232	PMC-2HS-USB
Teaching unit (Sold separately)	Adding operation mode, parameter, program drive handling (Scan operation, program execution, home search, etc)			
Common output	1 point		2 point	
Control interface	Parallel I/F			
Environment	Ambient temperature	0 to 45°C		
	Ambient humidity	35 to 85%RH		
Accessory	Common	User manual & CD		
	Power connector	CN1: MC1,5/2-ST-3.5 (PHOENIX) 1EA		
	RS232C connector	CN2: RS-232C communication cable (1.5m) 1EA		
	P I/F connector	CN3: 20P MIL standard, 2.54mm connector 1EA		
	X axis input/ output connector	CN4: 16P MIL standard, 2.54mm connector 1EA (2HS: 2EA)		
	Y axis input/ output connector	—		CN5: 16P MIL standard, 2.54mm connector 1
	USB connector	—	USB communication cable (1m) 1EA	—
Unit weight	Approx. 96g		Approx. 102g	

※Environment resistance is rated at no freezing of condensation.

## Driver Operation

- Operation by Parallel I/F  
Connect sequence controller or switch to Parallel I/F.
- Operation by PC  
Connect PC and controller with communication cable and run dedicated program (MotionStudio).
- Operation by teaching unit (PMC-2TU-232)  
Connect teaching unit cable and install JOG output, HOME search using operation button.
- Operation by serial communication (Using serial communication protocol)  
Using serial communication protocol, operate according to program writing by user.

## Commands In The Operation Program

Command type	Code	Description
Drive commands	ABS	Move absolute position
	INC	Move incremental position
	HOM	Home search
I/O commands	IJP	Jump input condition
	OUT	ON/OFF of output port
	OTP	ON pulse from output port
Program control commands	JMP	Jump
	REP	Start repetition
	RPE	End repetition
Others	END	End program
	NOP	No operation

## Unit Descriptions

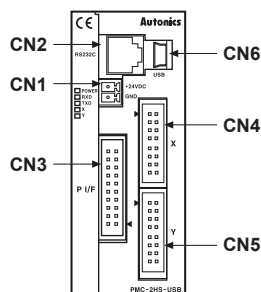

Connector No	Description
CN1	Power connector
CN2	RS232C connector (Connect to PMC-2TU-232)
CN3	Parallel I/F connector
CN4	X-Axis I/O connector
CN5	Y-Axis I/O connector
CN6	USB connector

※PMC-1HS type does not have I/O connector (CN5) of Y axis.

(A) Photoelectric Sensors

(B) Fiber Optic Sensors

(C) Door/Area Sensors

(D) Proximity Sensors

(E) Pressure Sensors

(F) Rotary Encoders

(G) Connectors/ Sockets

(H) Temperature Controllers

(I) SSRs / Power Controllers

(J) Counters

(K) Timers

(L) Panel Meters

(M) Tacho / Speed / Pulse Meters

(N) Display Units

(O) Sensor Controllers

(P) Switching Mode Power Supplies

(Q) Stepper Motors & Drivers & Controllers

(R) Graphic/ Logic Panels

(S) Field Network Devices

(T) Software

# PMC-1HS/PMC-2HS Series

## ■ Power Connector (CN1)

Pin No.	Signal name
1	24VDC
2	GND (0V)

## ■ RS232C Serial I/F Connector (CN2)

Pin No.	Signal name	Input/Output	Description
1	TXD	Output	Receiving data
2	RXD	Input	Transmitting data
3	GND	—	Ground
4	—	—	No-connection
5	—	—	No-connection
6	—	—	No-connection

(Note) The internal connection diagram of RS232C communication cable is shown as below.

<CN3 Pin No.>

20 ■ ■19
18 ■ ■17
16 ■ ■15
14 ■ ■13
12 ■ ■11
10 ■ ■9
8 ■ ■7
6 ■ ■5
4 ■ ■3
2 ■ ■1

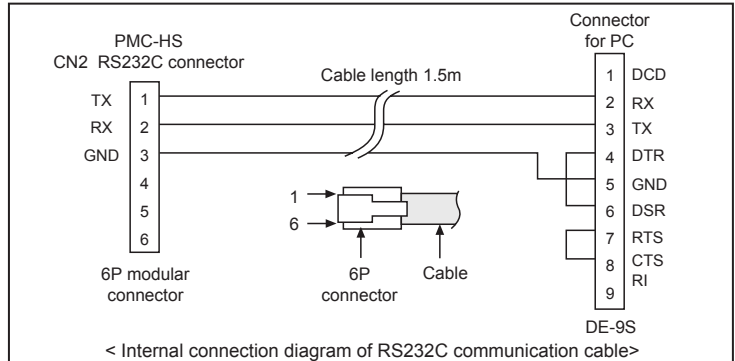

## ■ Parallel I/F Connector (CN3)

The Parallel I/F connector which is connected with a sequencer or mechanical contacts operates motion controller same as PC program. When input signal is ON, the input signal terminal and GEX terminal are connected by mechanical contacts or open collector output etc. and open collector output transistor is ON when the output signal is ON.

Pin No.	Signal name	Input/Output	Description
1	RESET	Input	Reset
2	HOME	Input	Home search start command
3	STROBE	Input	Drive start command
4	X/SCAN Y+	Input	X-axis specification/Scan Y+
5	Y/SCAN Y-	Input	Y-axis specification/Scan Y-
6	REGSL0/RUN+/SCAN X+	Input	Register specification 0/Run+/Scan X+
7	REGSL1/RUN-/SCAN X-	Input	Register specification 1/Run-/Scan X-
8	REGSL2/SPD0	Input	Register specification 2/Drive speed specification 0
9	REGSL3/SPD1	Input	Register specification 3/Drive speed specification 1
10	REGSL4/SCAN	Input	Register specification 4/Scan specification
11	REGSL5/STOP	Input	Register specification 5/Drive stop
12	MODE0	Input	Operation mode specification 0
13	MODE1	Input	Operation mode specification 1
14	X DRIVE/END	Output	X-axis drive/Drive end pulse
15	Y DRIVE/END	Output	Y-axis drive/Drive end pulse
16	X ERROR	Output	X-axis error
17	Y ERROR	Output	Y-axis error
18	GEX	0V	Ground
19	GEX	0V	Ground
20	VEX	+24V	Power supply for sensor (24VDC, Max. 100mA)

# 1-2-Axis High Speed Programmable Motion Controller

## Input/Output Connections (CN3)

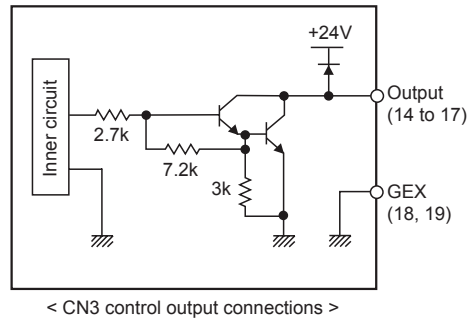
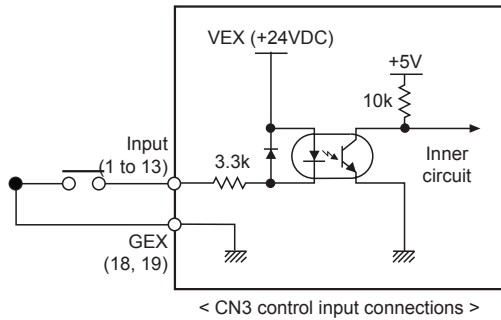

## X, Y-Axis Input/Output Connector (CN4, CN5)

CN4 and CN5 are I/O signals for X-Axis and Y-Axis respectively. The pin arrangement of CN4 and CN5 are equal. PMC-1HS does not have CN5. 'n' in the table means X for CN4 and Y for CN5.

Pin No.	Signal name	Input/Output	Description
1	nP+P	Output	Drive pulse in the CW + direction
2	nP+N	Output	Drive pulse in the CW + direction
3	nP-P	Output	Drive pulse in the CCW - direction
4	nP-N	Output	Drive pulse in the CCW - direction
5	n OUT0	Output	General output0/DCC
6	n INPOS	Input	Finish the servo inposition
7	n ALARM	Input	Servo alarm
8	GEX	0V	Ground
9	n STOP2	Input	Encoder Z-phase
10	n STOP1	Input	Home
11	n STOP0	Input	Near Home
12	n LMT+	Input	LMT+
13	n LMT-	Input	LMT-
14	EMG	Input	Emergency stop
15	GEX	0V	Ground
16	VEX	+24V	Power supply for sensor (24VDC, Max. 100mA)

<CN4, CN5 Pin No>

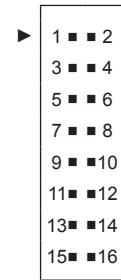

※CN4, 5 input/output is same as CN3 input/output connections.

Drive pulse output of motion controller which is input to motor driver is line driver output.

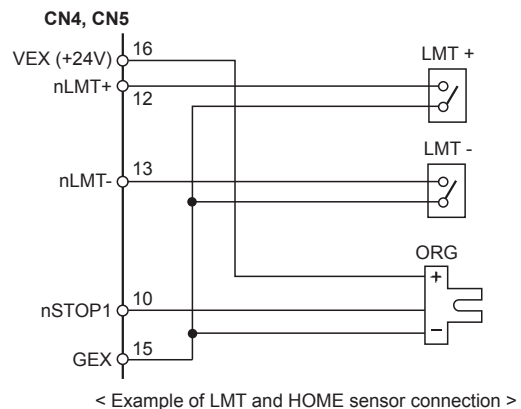
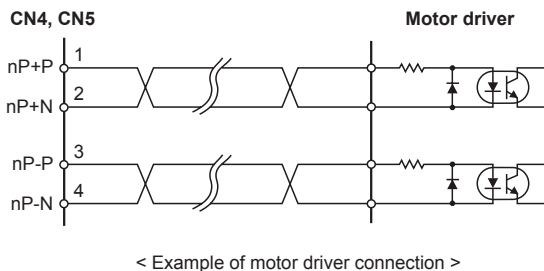

- (A) Photoelectric Sensors
- (B) Fiber Optic Sensors
- (C) Door/Area Sensors
- (D) Proximity Sensors
- (E) Pressure Sensors
- (F) Rotary Encoders
- (G) Connectors/ Sockets
- (H) Temperature Controllers
- (I) SSRs / Power Controllers
- (J) Counters
- (K) Timers
- (L) Panel Meters
- (M) Tacho / Speed / Pulse Meters
- (N) Display Units
- (O) Sensor Controllers
- (P) Switching Mode Power Supplies
- (Q) Stepper Motors & Drivers & Controllers
- (R) Graphic/ Logic Panels
- (S) Field Network Devices
- (T) Software

# PMC-1HS/PMC-2HS Series

## ■ Connections

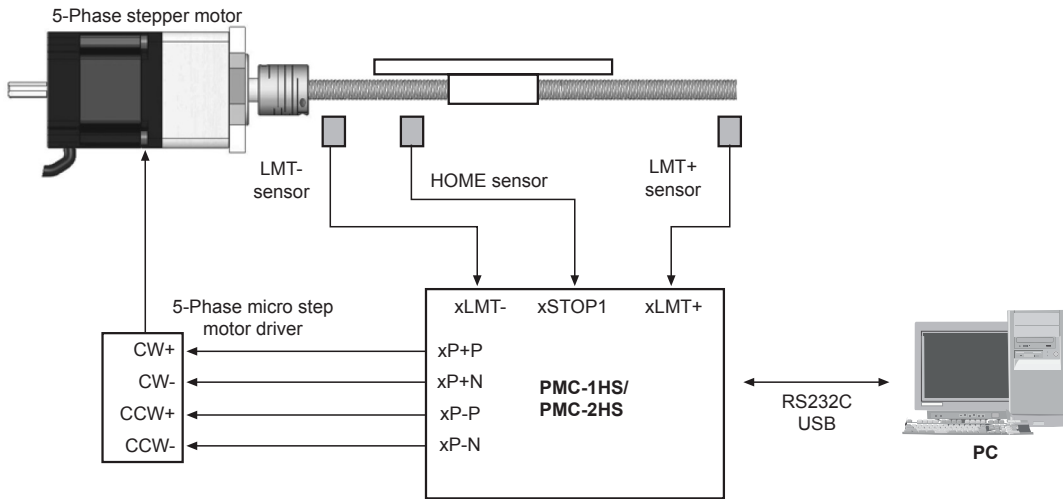

< Basic configuration of the motion controller (configuration only for X-axis) >

## ■ Dimensions

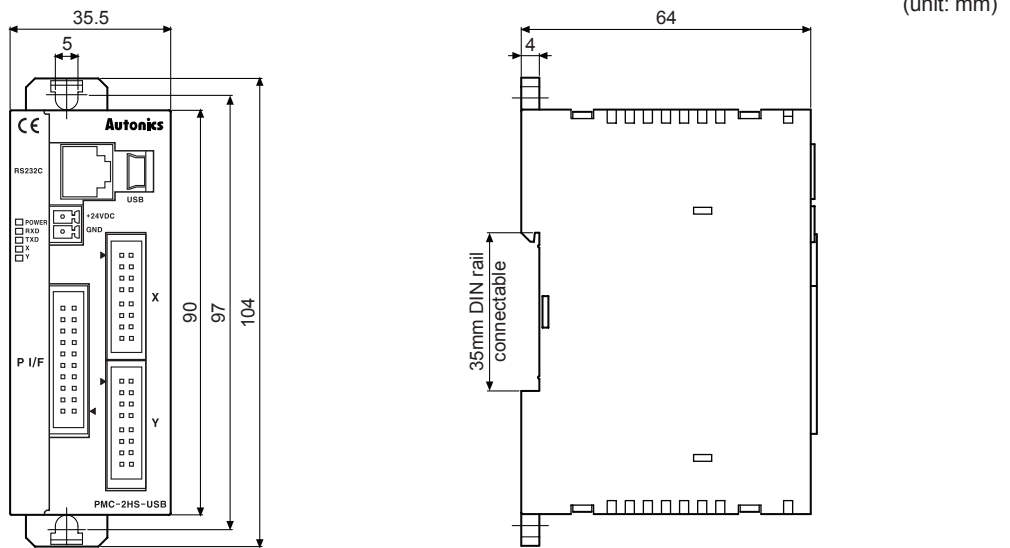

## ■ Teaching unit PMC-2TU-232 (sold separately)

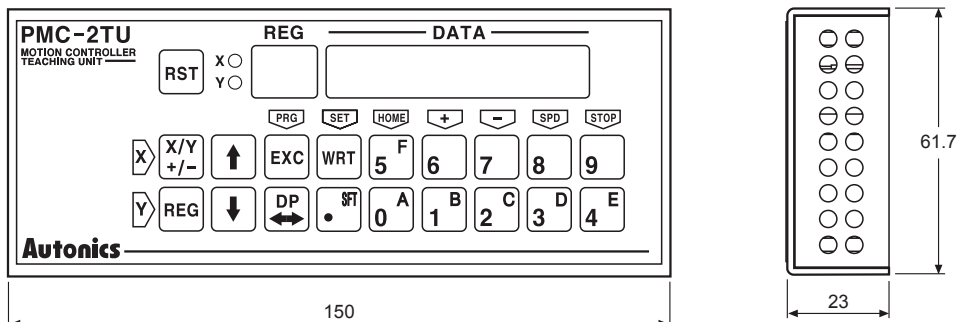

# 1-2-Axis High Speed Programmable Motion Controller

## ■ Teaching Unit PMC-2TU-232 (Sold Separately)

Teaching unit (PMC-2TU-232) is a device to arrange the operation mode, parameter and operation program without PC and it is also able to install start the operation program, HOME search and JOG operation. Connect to RS232C connector (CN2) using a cable (1.5m)

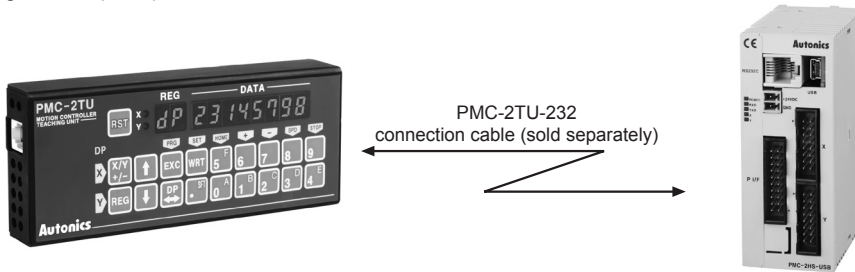

Teaching unit consists of data edit mode and drive operation mode. The register number is displayed on REG of data edit mode and dp (drive operation) is displayed in drive operation mode and it will be a drive operation status when applying power. Use DP key to convert the status of data edit mode and drive operation mode.

Mode	Operation	REG display
Data edit	<ul style="list-style-type: none"> <li>Record operation mode parameter and operation program</li> <li>Installation of index drive</li> </ul>	Register number
Drive handling	<ul style="list-style-type: none"> <li>Displaying the current position</li> <li>JOG operation</li> <li>HOME search</li> <li>Installation of program</li> </ul>	<p>dp</p> <p>(drive operation)</p>

The front panel of the teaching unit shown as below;

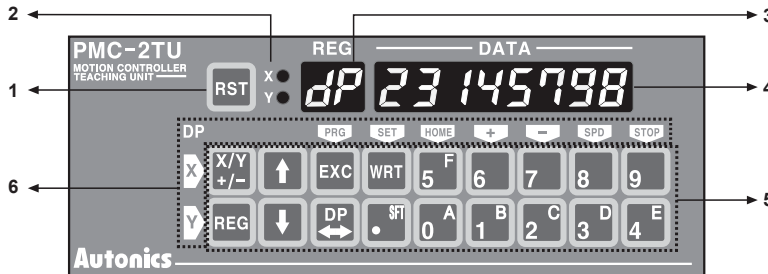

- Reset:** Reset the controller and teaching unit.
- X/Y display:** Display the current axis.
- Register number display/dp:** Display the current register number when editing data and dp when operating drive.
- Data display:** Display the data of each register when data editing and the current position of the axis when operating drive.
- Input key**
  - X/Y: Convert the axis and the sign of input value and it is used to change mode data when inputting mode.
  - REG: Input the register number to display and it is returned to previous step pressing a key during data input.
  - ↑↓: Increase or decrease the current register number.
  - EXC: Install the current command, but, ABS, INC, OUT, HOM1 to 4 are only valid.
  - DP: Convert the status of driver operation and data edit.
  - WRT: Enter a value when editing data.
- Display the key for drive operation:** Display the key function on a left and upside of the key as a yellow letter and the upper part operates X axis and the lower part operates Y axis.

(A)	Photoelectric Sensors
(B)	Fiber Optic Sensors
(C)	Door/Area Sensors
(D)	Proximity Sensors
(E)	Pressure Sensors
(F)	Rotary Encoders
(G)	Connectors/ Sockets
(H)	Temperature Controllers
(I)	SSRs / Power Controllers
(J)	Counters
(K)	Timers
(L)	Panel Meters
(M)	Tacho / Speed / Pulse Meters
(N)	Display Units
(O)	Sensor Controllers
(P)	Switching Mode Power Supplies
(Q)	Stepper Motors & Drivers & Controllers
(R)	Graphic/ Logic Panels
(S)	Field Network Devices
(T)	Software