

PMC-2HSP/PMC-2HSN Series

2-Axis High Speed Interpolation/Normal Motion Controller

■ Features

- Independent 2-Axis controlling with high operating speed of max. 4Mpps
- Linear/Circular interpolation control (PMC-2HSP)
- Realizing a wide variety of operation up to 200 steps using 17 different operation programs (13 commands except circular/linear interpolation command for PMC-2HSN series)
- Various control interface available (USB, RS232C, RS485, Parallel I/F)
- Controlling up to 32 axis (16 units) via RS485 serial communication (Modbus RTU)
- 4 operation modes: Jog, Continuous, Index, Program mode
- Symmetrical/asymmetrical trapezoid, S-shaped de/acceleration driving function

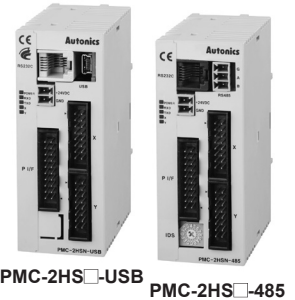

⚠ Please read "Caution for your safety" in operation manual before using.



(except for PMC-2HS□-485)

■ User Manual

- Please refer to user manual for detailed instructions and specifications.
- Visit our web site (www.autonics.com) to download user manual and software [MotionStudio].
- User manual describes installing software, setting parameter and program, operation mode, and multi-axis operation, etc. to operate motion controller.

■ Software (MotionStudio)

MotionStudio is the windows software designed to operate motion control for PMC-2HSP/2HSN series.

- Compatible Microsoft Windows 98, NT, 2000, XP (32bit, 64bit), Vista (32bit, 64bit) and 7 (32bit, 64bit)
- Supports 9,600, 19,200, 38,400, 57,600, 115,200 bps transmission speeds
- Available to use on all OS supported COM ports (COM1 to COM256)
- Multilingual support (Korean, English)
- Provides a calculator for convenience (Calculates PPS, center of interpolation, end coordinates)

■ Ordering Information

PMC	-	2HSP	-	USB	
				Communication type	
				Axis/Type	
				Item	
				485	RS485 / RS232C
				USB	USB / RS232C
				2HSP	2-Axis high speed interpolation
				2HSN	2-Axis high speed normal
				PMC	Programmable Motion Controller

■ Specifications

Model	PMC-2HSP-USB	PMC-2HSP-485	PMC-2HSN-USB	PMC-2HSN-485			
Control axis	2-Axis						
Motor for control	Pulse string input stepper motor or servo motor						
Power supply	24VDC						
Power consumption	Max. 6W						
Inposition range	-8,388,608 to 8,388,607 (selectable absolute/relative value, available pulse-scaling function)						
Range for the drive speed	1 pps to 4 Mpps (1 to 8,000pps × Magnification 1 to 500)						
Output pulse type	1 Pulse/2 Pulse output (line driver)						
RUN mode	Scan/Continuous/Index (number of index: 64EA)						
	P program mode	Power on program start function / Program step: 200 step					
		ABS	Move absolute position	RID	2-Axis CCW arc interpolation*1	IRD	Stand-by external input
		INC	Move relative position	TIM	Timer	OPC	ON/OFF output port
		HOM	Home search	JMP	Jump	OPT	ON pulse from output port
		LID	2-Axis CCW linear interpolation*1	REP	Start repetition	NOP	No Operation
		CID	2-Axis CW circular interpolation*1	RPE	End repetition	END	End program
FID	2-Axis CW arc interpolation*1	ICJ	Jump input condition				
Home search mode	4 Step: High speed near home search, Low speed home search, Low speed Z-phase search, High speed offset movement Power on home search function						
I/O	• Parallel I/F (CN3): Input 13EA, Output 4EA • X-axis (CN 4) / Y-axis (CN 5): Input 8EA, Output 6EA (general-purpose I/O, 2EA each)						
Environment	Ambient temperature	0 to 45°C, storage: -15 to 70°C					
	Ambient humidity	20 to 90%RH					
Accessory	• [Common] Power connector, I/O connector (P I/F, X-axis, Y-axis), RS232C communication cable (1.5m) 1EA, Manual • [USB type] USB communication cable 1m 1EA • [RS485 type] RS485 connector 1EA						
Unit weight	Approx. 102g	Approx. 101g	Approx. 102g	Approx. 101g			

*1: These commands are only for PMC-2HSP series.

* Environment resistance is rated at no freezing of condensation.

2-Axis High Speed Interpolation/Normal Motion Controller

Basic Operation

There are two ways to operate motion controller.

- Using PC (MotionStudio)
 - Operates by connecting PC and the motion controller with communication cable and running MotionStudio.
- Using Parallel I/F
 - Operates by connecting sequence controller or switch to Parallel I/F.

Commands In The Operation Program

Command type	Code	Description
Drive commands	ABS	Move absolute position
	INC	Move relative position
	HOM	Home search
	LID	2-Axis linear interpolation
	CID	2-Axis CW circular interpolation ^{※1}
	FID	2-Axis CW arc interpolation ^{※1}
I/O commands	RID	2-Axis CCW arc interpolation ^{※1}
	ICJ	Jump input condition
	IRD	Stand-by external input
	OPC	ON/OFF output port
Program control commands	OPT	ON pulse from output port
	JMP	Jump
	REP	Start repetition
	RPE	End repetition
Others	END	End program
	TIM	Timer
	NOP	No operation

※1: These commands are only for PMC-2HSP series.

Unit Descriptions

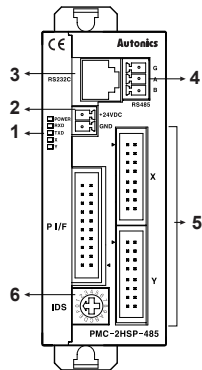

- Power / Status indicator**
Used to indicate power, controller's communication status and operation status for each axis
- Power connector terminal**
Used to connect power for controller
- RS232C connector terminal**
Used to connect RS232 serial (RJ12-DSUB9) connection cable
- USB/RS485 connector terminal**
Used to connect USB and RS485 connection cable
- External I/O connector terminal**
Used to operate various drives through input and output of Parallel I/F, X, Y
- ID select switch**
Used to set unique ID for each node in case of RS485 communication

Explanation Of Input/Output Terminal

PMC-2HS□-USB

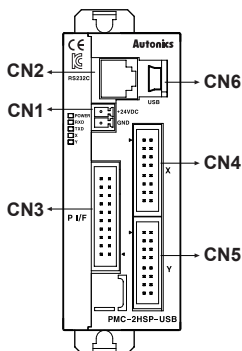

PMC-2HS□-485

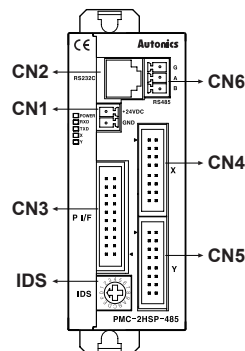

Connector No.	Description
CN1	Power connector
CN2	RS232C connector
CN3	Parallel I/F connector
CN4	X-Axis I/O connector
CN5	Y-Axis I/O connector
CN6	PMC-2HSP/2HSN-USB: USB connector
	PMC-2HSP/2HSN-485: RS485 connector
IDS	ID selection switch

- (A) Photoelectric Sensors
- (B) Fiber Optic Sensors
- (C) Door/Area Sensors
- (D) Proximity Sensors
- (E) Pressure Sensors
- (F) Rotary Encoders
- (G) Connectors/ Sockets
- (H) Temperature Controllers
- (I) SSRs / Power Controllers
- (J) Counters
- (K) Timers
- (L) Panel Meters
- (M) Tacho / Speed / Pulse Meters
- (N) Display Units
- (O) Sensor Controllers
- (P) Switching Mode Power Supplies
- (Q) Stepper Motors & Drivers & Controllers
- (R) Graphic/ Logic Panels
- (S) Field Network Devices
- (T) Software

PMC-2HSP/PMC-2HSN Series

■ Power Connector (CN1)

Pin No.	Signal name
1	24VDC
2	GND (0V)

<CN3 Pin No>

20	■	19
18	■	17
16	■	15
14	■	13
12	■	11
10	■	9
8	■	7
6	■	5
4	■	3
2	■	1

■ RS232C Connector (CN2)

Pin No.	Signal name	Input/Output	Description
1	TXD	Output	Receiving data
2	RXD	Input	Transmitting data
3	GND	—	Ground
4	—	—	No-connection
5	—	—	No-connection
6	—	—	No-connection

(Note) The internal connection diagram of RS232C communication cable is shown as below.

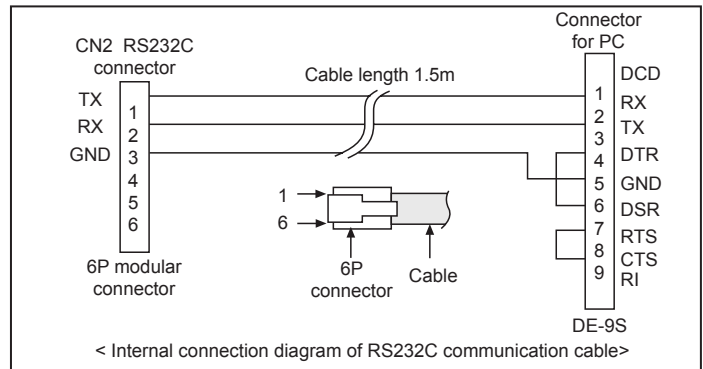

■ Parallel I/F Connector (CN3)

The Parallel I/F connector which is connected with a sequencer or mechanical contacts operates motion controller same as PC program. When input signal is ON, the input signal terminal and GEX terminal are connected by mechanical contacts or open collector output and open collector output transistor is ON when the output signal is ON.

Pin No.	Signal name	Input/Output	Description
1	RESET	Input	Reset
2	HOME	Input	Home search start command
3	STROBE	Input	Drive start command
4	X/SCAN Y+	Input	X-axis specification/Scan Y+
5	Y/SCAN Y-	Input	Y-axis specification/Scan Y-
6	STEPSL0/RUN+/JOG X+	Input	Register specification 0/Run+/Scan X+
7	STEPSL1/RUN-/JOG X-	Input	Register specification 1/Run-/Scan X-
8	STEPSL2/SPD0	Input	Register specification 2/Drive speed specification 0
9	STEPSL3/SPD1	Input	Register specification 3/Drive speed specification 1
10	STEPSL4/JOG	Input	Register specification 4/Scan specification
11	STEPSL5/STOP	Input	Register specification 5/Drive stop
12	MODE0	Input	Operation mode specification 0
13	MODE1	Input	Operation mode specification 1
14	X DRIVE/END	Output	X-axis drive/Drive end pulse
15	Y DRIVE/END	Output	Y-axis drive/Drive end pulse
16	X ERROR	Output	X-axis error
17	Y ERROR	Output	Y-axis error
18	GEX	0V	Ground
19	GEX	0V	Ground
20	VEX	+24V	Power supply for sensor (24VDC, Max. 100mA)

2-Axis High Speed Interpolation/Normal Motion Controller

Input/Output Connections (CN3)

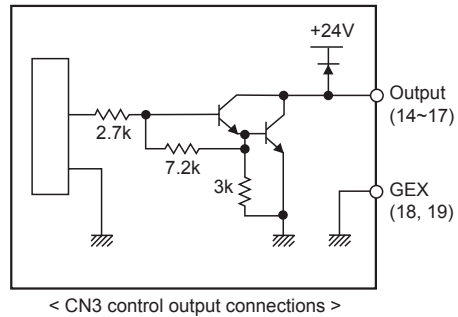
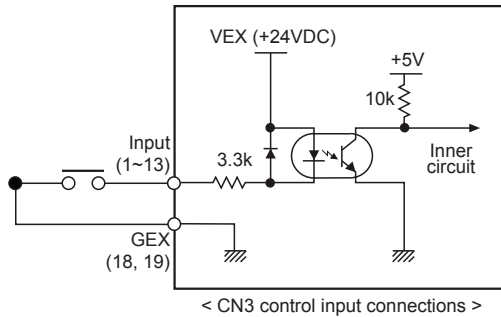

X, Y-Axis Input/Output Connector (CN4, CN5)

CN4 and CN5 are I/O signals for X-Axis and Y-Axis respectively.

The pin arrangement of CN4 and CN5 are equal. 'n' in the table means X for CN4 and Y for CN5.

Pin No.	Signal name	Input/Output	Description
1	n P+P	Output	Drive pulse in the CW + direction
2	n P+N	Output	Drive pulse in the CW + direction
3	n P-P	Output	Drive pulse in the CCW - direction
4	n P-N	Output	Drive pulse in the CCW - direction
5	n OUT0	Output	General output 0
6	n OUT1	Output	General output 1
7	n IN0	Input	General input 0
8	n IN1	Input	General input 1
9	n STOP2	Input	Encoder Z-phase
10	n STOP1	Input	Home
11	n STOP0	Input	Near Home
12	n LMT+	Input	LMT+
13	n LMT-	Input	LMT-
14	EMG	Input	Emergency stop
15	GEX	0V	Ground
16	VEX	+24V	Power supply for sensor (24VDC, Max. 100mA)

<CN4, CN5 Pin No>

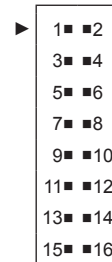

※CN4, 5 input/output is same as CN3 input/output connections.

Drive pulse output of motion controller which is inputted to motor driver is line driver output.

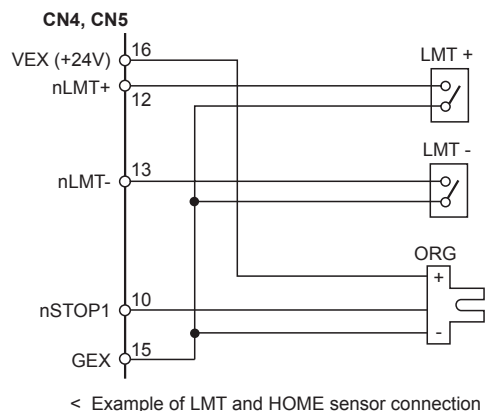
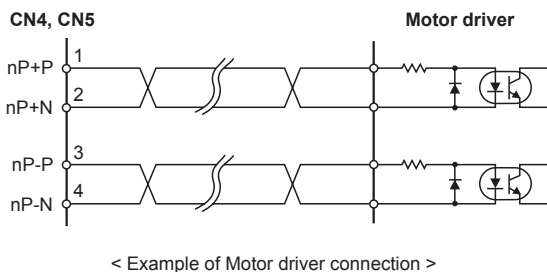

- (A) Photoelectric Sensors
- (B) Fiber Optic Sensors
- (C) Door/Area Sensors
- (D) Proximity Sensors
- (E) Pressure Sensors
- (F) Rotary Encoders
- (G) Connectors/ Sockets
- (H) Temperature Controllers
- (I) SSRs / Power Controllers
- (J) Counters
- (K) Timers
- (L) Panel Meters
- (M) Tacho / Speed / Pulse Meters
- (N) Display Units
- (O) Sensor Controllers
- (P) Switching Mode Power Supplies
- (Q) Stepper Motors & Drivers & Controllers
- (R) Graphic/ Logic Panels
- (S) Field Network Devices
- (T) Software

PMC-2HSP/PMC-2HSN Series

RS485 Connector (CN6)

Pin No.1	Signal name	Input/Output	Description
1	B (-)	I/O	Transmitting / Receiving data
2	A (+)	I/O	Transmitting / Receiving data
3	G	-	※1

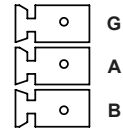

※1: Connect the ground when it is required depending on communication environments.

Connections

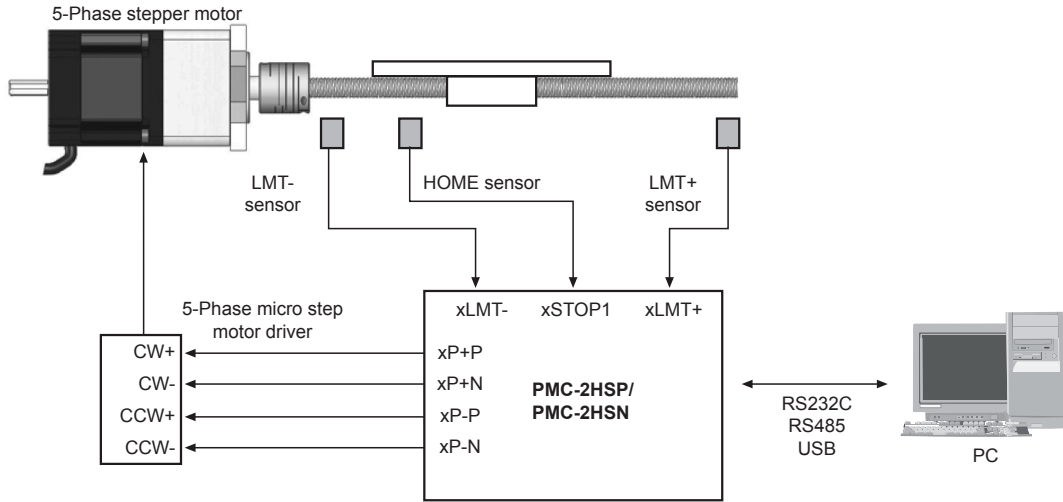

< Basic configuration of the motion controller (Configuration only for X-axis) >

Dimensions

(unit: mm)

