

# MD5-HD14-2X, 3X Multi-Axis 5-Phase Stepper Motor Driver

## Low Noise, Low Vibration Multi Axis 5-Phase Stepper Motor Driver

### ■ Features

- Simultaneous operation of 2, 3-axis by single power supply 20-35VDC
- Small, light weight and advanced quality by custom IC and surface mounted circuit
- Realizing low noise, low vibration rotation with microstep-driving
- Low speed rotation and high accuracy controlling with microstep-driving
- Max. resolution - 250 division: In case of 5-phase stepper motor of which basic step angle is 0.72°, it enables to control up to 0.00288° per pulse
- Includes auto current down and self-diagnosis function
- Photocoupler input insulation method to minimize the effects from external noise

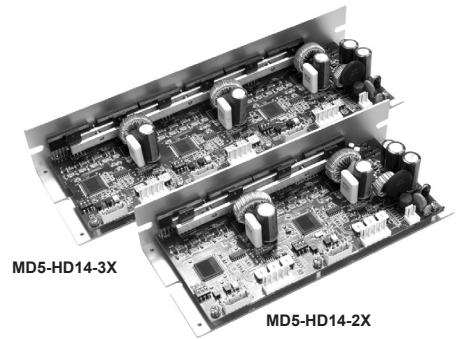

**⚠ Please read "Caution for your safety" in operation manual before using.**



### ■ Ordering Information

MD	5	-	H	D	14	-	2X	
Item	Motor phase		Step type (Resolution)	Power supply	RUN current		Axis	
	5		H	D	14		2X	2-axis
							3X	3-axis
							14	1.4A/Phase
							D	20-35VDC
							H	Micro step (250 divisions)
							5	5-Phase
							MD	Motor Driver

※Built-in zero point excitation output signal is optional.

### ■ Specifications

Model	MD5-HD14-2X	MD5-HD14-3X
Power supply	Max. 20-35VDC 5A (-10%, +20%) <sup>※1</sup>	Max. 20-35VDC 7A (-10%, +20%)
RUN current	0.4 to 1.4A / Phase	
RUN method	Bipolar constant current pentagon drive	
Basic step angle	0.72° / 1Step	
Resolution	1, 2, 4, 5, 8, 10, 16, 20, 25, 40, 50, 80, 100, 125, 200, 250 division (0.72° to 0.00288° / 1Step)	
Input pulse width	Min. 0.5μs	
Pulse duty	50%	
Rising/Falling time	Max. each 120ns	
Max. input pulse frequency	1MHz	
Input voltage level	High: 4-8VDC, Low: 0-0.5VDC	
Input resistance	270Ω (CW, CCW). 390Ω (HOLD OFF)	
Environ-ment	Ambient temperature	0 to 40°C, storage: -20 to 60°C
	Ambient humidity	30 to 85%RH, storage: 30 to 85%RH
Approval	CE	
Unit weight	Approx. 292g	Approx. 411g

※1: When using over 30VDC, it should be mounted at ventilated place due to increasing heat.

※Environment resistance is rated at no freezing of condensation.

(A) Photoelectric Sensors

(B) Fiber Optic Sensors

(C) Door/Area Sensors

(D) Proximity Sensors

(E) Pressure Sensors

(F) Rotary Encoders

(G) Connectors/ Sockets

(H) Temperature Controllers

(I) SSRs / Power Controllers

(J) Counters

(K) Timers

(L) Panel Meters

(M) Tacho / Speed / Pulse Meters

(N) Display Units

(O) Sensor Controllers

(P) Switching Mode Power Supplies

(Q) Stepper Motors & Drivers & Controllers

(R) Graphic/ Logic Panels

(S) Field Network Devices

(T) Software

# MD5-HD14-2X, 3X

## ◎ Function selection switch



NO	Name	Function	Switch position	
			ON	OFF
1	TEST	Self-diagnosis	Rotate in 30rpm	Not using
2	1/2 CLK	Pulse input method	1-pulse input	2-pulse input
3	C/D	Auto current down	Not using	Using

### ● TEST

※Self-diagnosis function is to test motors and drivers.

※Motors rotate with 30 rpm in full-step. Motor rotation speed is subject to change depending on resolution setting.

※Rotation speed = 30 rpm / resolution

※The motor will rotate in CCW direction when in 1-pulse input mode and in CW direction when in 2-pulse input mode.

Note) Make sure that TEST switch is set to OFF before supplying the power.

It may cause injury or danger if TEST switch is set to ON when power is supplied.

### ● 1/2 CLK

※1/2 CLK switch is to select pulse input mode.

※1-pulse input mode: CW → operation command pulse input, CCW → rotation direction pulse input

([H]: CW rotation, [L]: CCW rotation)

※2-pulse input mode: CW → CW direction rotation pulse input, CCW → CCW direction rotation pulse input

### ● C/D (Auto current down)

※This function is reducing current automatically according to STOP current setting value in order to suppress generated heat when motor is stop.

※After inputting the last pulse, current is decreased after approx. 500ms.

## ◎ RUN current setting

S/W No	0	1	2	3	4	5	6	7	8	9	A	B	C	D	E	F
Current (Arms/Phase)	0.4	0.5	0.57	0.63	0.71	0.77	0.84	0.9	0.96	1.02	1.09	1.15	1.22	1.27	1.33	1.4

※RUN current is a phase current provided to 5-phase stepper motor.

※Be sure to set RUN current at the rated current or below.

※ Adjust the RUN current in case severe heat generation occurs. Be sure that torque decreasing may occur when adjusting the current.

Note) Be sure to adjust RUN current while motor is running.

## ◎ STOP current setting

S/W No	0	1	2	3	4	5	6	7	8	9	A	B	C	D	E	F
%	27	31	36	40	45	50	54	58	62	66	70	74	78	82	86	90

※STOP current is a phase current provided to 5-phase stepper motor at standstill.

※It will be activated when C/D (Auto current down) is set to ON. By setting STOP current, it is possible to suppress the heat generation at motor standstill.

※STOP current setting value is the ratio of RUN current setting value (%).

E.g.) In case RUN current setting value is set to 1.4A and STOP current setting value is set to 50%, auto current down current is set to 0.7A.

※STOP current setting value may have some deviation depending on resistance impedance of motor.

※Auto current down function will be activated when HOLD OFF signal is [L]. When HOLD OFF signal is [H], the function is not activated since the current provided to each phase is cut off.

Note) Be sure to adjust STOP current while motor is at standstill.

## ◎ Zero point excitation output signal (ZERO OUT)[※Option]

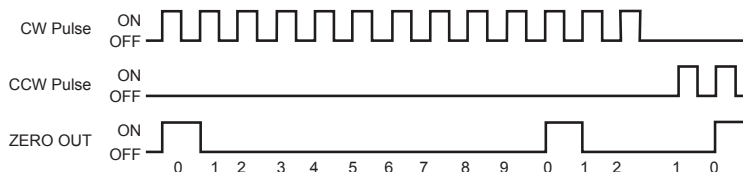

※The signal is output to indicate when the motor excitation status is in the initial stage. / Used to check the rotation position of motor's axis.

※In case of full step, the signal is output every 7.2°. (50 times / rotation)

E.g.) Full step (0.72°/Step): Signal is output every 10 pulses.

20 divisions (0.036°/Step): Signal is output every 200 pulses.

# Multi-Axis 5-Phase Stepper Motor Driver

## Ⓞ HOLD OFF function

※When HOLD OFF input signal is [H], motor excitation is released.

When HOLD OFF input signal is [L], motor excitation is in a normal status.

※A function used to rotate motor's axis using external force or used for manual positioning.

※HOLD OFF Input signal [H] and [L] represent Photocoupler ON/OFF in a circuit.

※Please do not use for stopping motor.

## Ⓞ Setting microstep (Microstep: Resolution)

S/W No	0	1	2	3	4	5	6	7	8	9	A	B	C	D	E	F
Resolution	1	2	4	5	8	10	16	20	25	40	50	80	100	125	200	250
Step angle	0.72°	0.36°	0.18°	0.144°	0.09°	0.072°	0.045°	0.036°	0.0288°	0.018°	0.0144°	0.009°	0.0072°	0.00576°	0.0036°	0.00288°

### ● Resolution setting (Same as MS1, MS2)

※Microstep is to make basic step angle of 5-phase motors (0.72°) divided into smaller angle according to setting values.

※The formula for microstep angle is ;

$$\text{Motor revolution angle (5-phase motors)} = \frac{\text{Basic step angle (0.72°)}}{\text{Resolution}}$$

※In case of geared motors, step angle shall be determined by dividing step angle by gear ratio.

E.g.)  $0.72 / 10 (1:10) = 0.072°$

※It may cause step-out if resolution is changed while motor is running.

## ■ Input-Output Diagram

<Inner circuit of MD5-HD14-2X/3X>

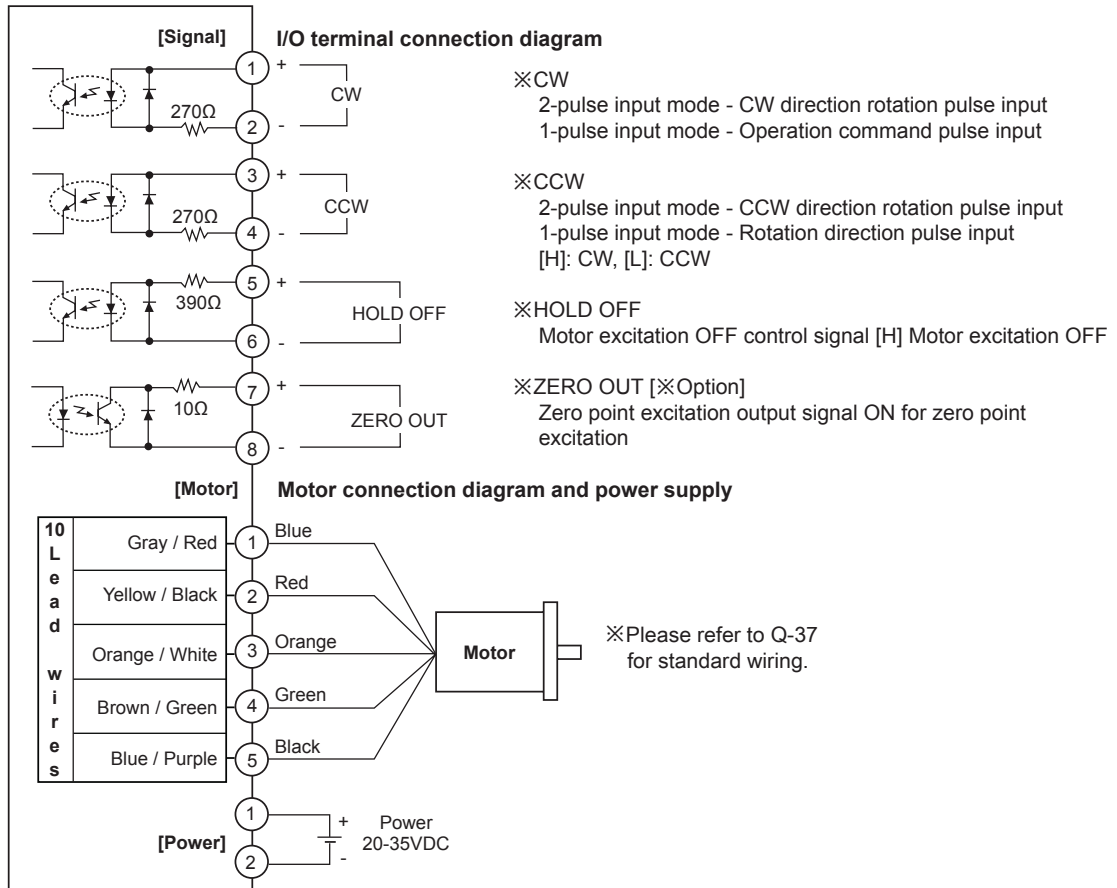

**Note)** Add external resistance when power for pulse from the external of the unit exceeds +5V. (Input current:10 to 20mA)

**Note)** 2/3-axis use power supply in common and input/output terminals are proportional to the number of axes of mode.

(A) Photoelectric Sensors

(B) Fiber Optic Sensors

(C) Door/Area Sensors

(D) Proximity Sensors

(E) Pressure Sensors

(F) Rotary Encoders

(G) Connectors/ Sockets

(H) Temperature Controllers

(I) SSRs / Power Controllers

(J) Counters

(K) Timers

(L) Panel Meters

(M) Tacho / Speed / Pulse Meters

(N) Display Units

(O) Sensor Controllers

(P) Switching Mode Power Supplies

(Q) Stepper Motors & Drivers & Controllers

(R) Graphic/ Logic Panels

(S) Field Network Devices

(T) Software

# MD5-HD14-2X, 3X

## ■ Dimensions

(unit: mm)

### ◎ MD5-HD14-2X

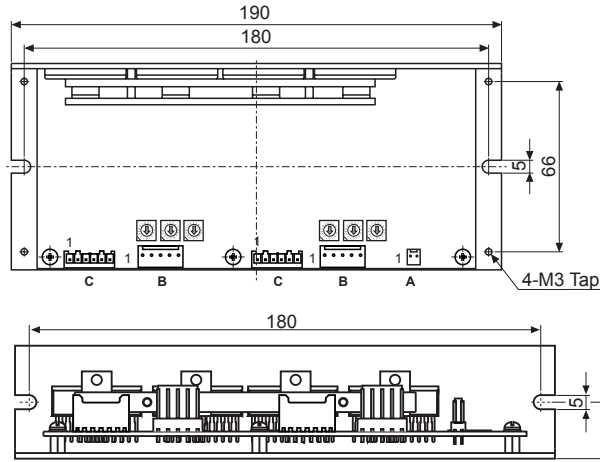

#### ※Accessory connector specification

Accessory	Connector		Qty.
	Manufacturer	Model No.	
A Power 2P Housing	Yeonho electronics	YH396-02V	1
B Motor 5P Housing	Yeonho electronics	YH396-05V	2
C Signal 6P Housing	JST	XAP-0.6V-1	2
— Power/Motor Terminal Pin	Yeonho electronics	YT396	12
— Signal Terminal Pin	JST	SXA-001T-P0.6	12

### ◎ MD5-HD14-3X

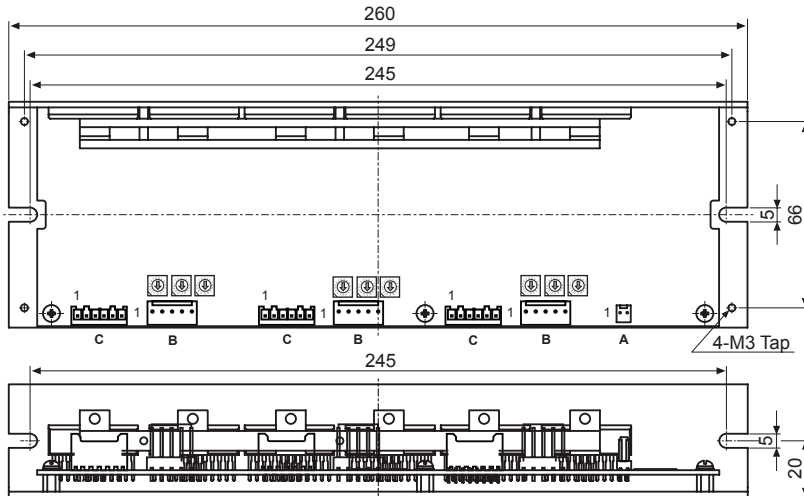

#### ※Accessory connector specification

Accessory	Connector		Qty.
	Manufacturer	Model No.	
A Power 2P Housing	Yeonho electronics	YH396-02V	1
B Motor 5P Housing	Yeonho electronics	YH396-05V	3
C Signal 6P Housing	JST	XAP-0.6V-1	3
— Power/Motor Terminal Pin	Yeonho electronics	YT396	17
— Signal Terminal Pin	JST	SXA-001T-P0.6	18