

# SCM Series

## SCM-US48I

USB to Serial converter (converting signal USB to Serial)

### ■ Features

- Available to transmit signals to max. 1.2km by converting USB signal to RS485 signal
- Realizing electrical insulation (2500V RMS) between USB port and RS485 port through RS485 transceiver.
- Improved stability and durability with built-in protection circuit
- Easy connections between devices with bus power supplied from USB host controller without external power supply
- Offering USB 2.0 A/B type cable with built-in ferrite core for noise reduction
- Various operating systems supported (Windows 98, 98SE, ME, 2000, Server 2003, XP, Vista, 7)
- User friendly features through compatibility with USB 1.1 and USB 2.0



## SCM-38I

RS232C to RS485 converter (converting signal RS232C to RS485)

### ■ Features

- Built-in surge protection circuit
- The insulation type of signal line (Insulating RS232C and RS485)
- Create Tx-Enable signal automatically



## SCM-US

USB to Serial converter (converting signal USB to Serial)

### ■ Features

- Applicable OS: Windows 98, 98SE, ME, 2000, Server 2003, XP, Vista, 7
- Both USB 1.1 and USB 2.0 compatible
- Data transmission / power supply indicating LED
- Easy to connect with PC
- Built-in protection circuit
- Ferrite core cable for noise reduction
- Non-isolation type



※Specifically designed to connect to particular Autonics and Konics products which support the PC loader port.

 Please read "Caution for your safety" in operation manual before using.

### ■ Comprehensive Device Management program (DAQMaster)

DAQMaster is the comprehensive device management program. Visit our website ([www.autonics.com](http://www.autonics.com)) and download DAQMaster.

Item	Minimum requirements
System	IBM PC compatible computer with Intel Pentium III or above
Operations	Microsoft Windows 98/NT/XP/Vista/7
Memory	256MB+
Hard disk	1GB+ of available hard disk space
VGA	Resolution: 1024×768 or higher
Others	RS-232 serial port (9-pin), USB port

# Communication Converter

## ■ Specifications

### ◎ SCM-US48I / SCM-38I / SCM-US

Model	<b>SCM-US48I</b>		<b>SCM-38I</b>	<b>SCM-US</b>
Power supply	5VDC USB bus Power		12-24VDC ± 10%	5VDC USB bus Power <sup>※1</sup>
Power consumption	Max. 1W		Max. 1.7W	Max. 1W
Max. com speed <sup>※2</sup>	1,200 to 115,200bps (Recommended: 9,600bps)			
Communication type	Half duplex type			
Available com. distance	USB: Max. 1m ± 30% RS485: Max.1.2km		Max. 1.2km	1.5m (not extension)
Multi-drop	Max. 31 multi-drop		—	
Protocol <sup>※2</sup>	Data bit	5 to 8 data bits		—
	Stop bit	1 or 2 stop bits		—
	Parity bit	None/Odd/Even		—
Connection type	USB: B type connector		RS232: D-sub 9Pin	USB: A type connector
	RS485: 4-wire screw terminal (2wire communication type)		Earphone jack (4 pole stereo phone plug)	
Isolation type	Isolation		Non-isolation	
Dielectric strength	<ul style="list-style-type: none"> <li>Between terminals and case: 200VAC 50/60Hz for 1 min.</li> <li>Between USB and RS485: 2500VAC 50/60Hz for 1 min.</li> </ul>		<ul style="list-style-type: none"> <li>Between terminals and case: 200VAC 50/60Hz for 1 min.</li> <li>Between RS232C and RS485: 2500VAC 50/60Hz for 1 min.</li> </ul>	
Insulation resistance	Min. 100MΩ (at 500VDC megger)			
Noise strength	±500V the square wave noise (pulse width: 1μs) by the noise simulator			
Vibration	Mechanical	0.75mm amplitude at frequency of 10 to 55Hz in each X, Y, Z direction for 1 hour		
	Malfunction	0.5mm amplitude at frequency of 10 to 55Hz in each X, Y, Z direction for 10 min.		
Shock	Mechanical	300m/s <sup>2</sup> (approx. 30G) in each X, Y, Z direction for 3 times		
	Malfunction	100m/s <sup>2</sup> (approx. 10G) in each X, Y, Z direction for 3 times		
Environ-ment	Ambient temperature	-10 to 55°C, storage: -20 to 60°C		
	Ambient humidity	35 to 85%RH, storage: 35 to 85%RH		
Approval	CE			
Accessory	USB 2.0 AB type connector (length: 1m)		—	
Unit weight	Approx. 34.5g		Approx. 46g	Approx. 41g

※1: USB bus power is supplied from PC or USB host controller.

※2: Protocol and communication speed are set by Hyper terminal. DAQMaster, ParaSet, Modbus Poll.

When communicating with Autonics products, set communication speed to 9,600bps.

※There might be some differences in the specification above depending on PC environment.

※Environment resistance is rated at no freezing or condensation.

## ■ Installations

### ◎ SCM-US48I & SCM-38I

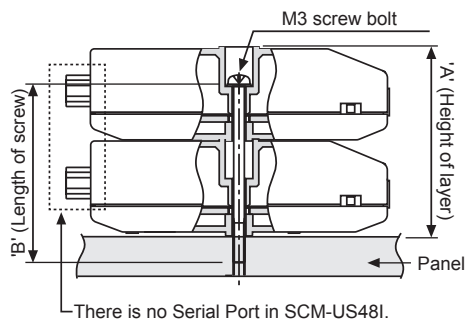

'B' (Length of screw)	"A" size (23N+0.5)	"B" size (23N-3)
1	23.5mm	20mm
2	46.5mm	43mm
3	69.5mm	66mm
4	92.5mm	89mm

(A) Photoelectric Sensors

(B) Fiber Optic Sensors

(C) Door/Area Sensors

(D) Proximity Sensors

(E) Pressure Sensors

(F) Rotary Encoders

(G) Connectors/ Sockets

(H) Temperature Controllers

(I) SSRs / Power Controllers

(J) Counters

(K) Timers

(L) Panel Meters

(M) Tacho / Speed / Pulse Meters

(N) Display Units

(O) Sensor Controllers

(P) Switching Mode Power Supplies

(Q) Stepper Motors & Drivers & Controllers

(R) Graphic/ Logic Panels

(S) Field Network Devices

(T) Software

# SCM Series

## ■ Dimensions

### ◎ SCM-US48I

※USB 2.0 AB type cable is including the product and is also sold separately.  
(model: USB AB CABLE)

(unit: mm)

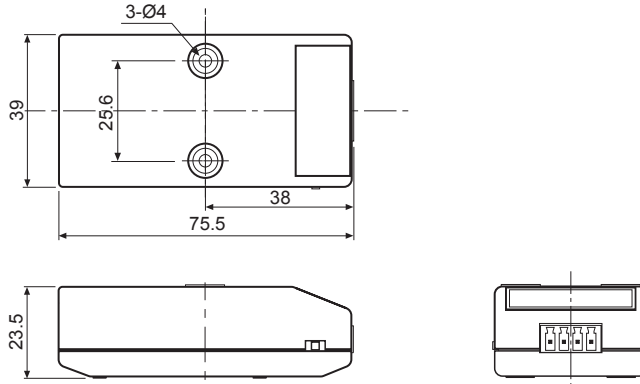

### ● USB 2.0 AB type cable

(unit: mm)

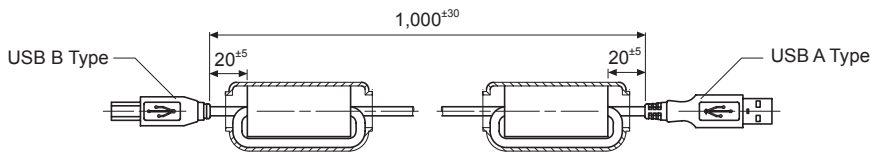

### ◎ SCM-38I

(unit: mm)

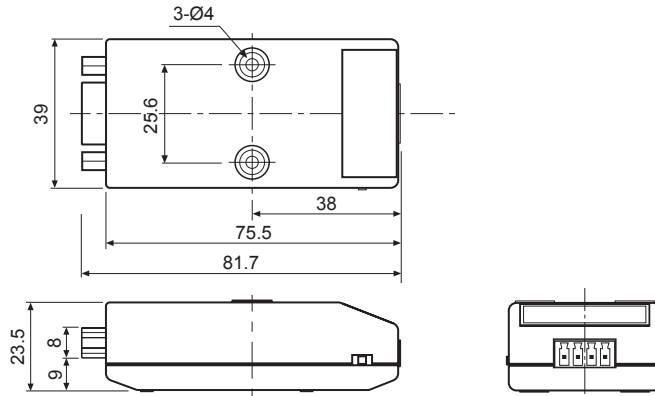

### ◎ SCM-US

(unit: mm)

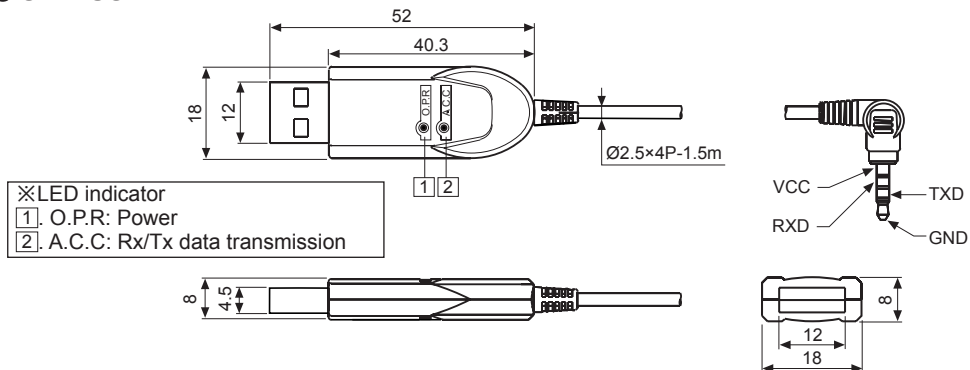

# Communication Converter

## Example Of Connections

### SCM-US481

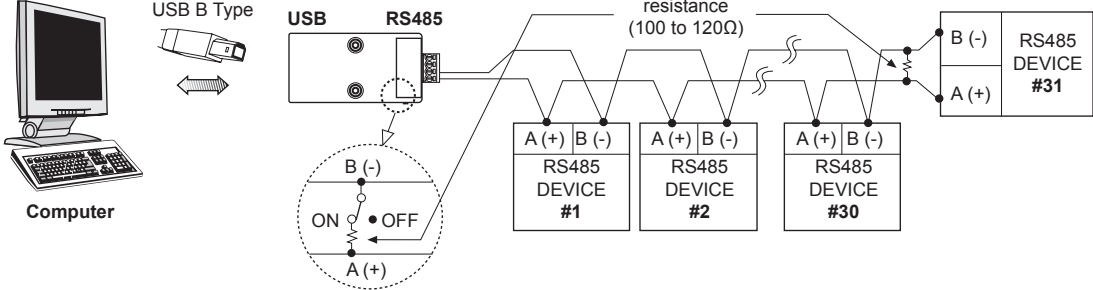

### SCM-381

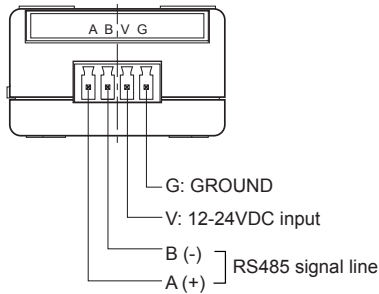

#### Terminating resistance selection

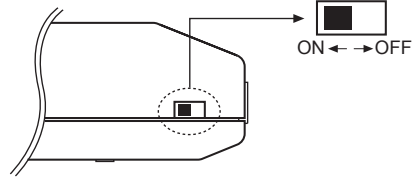

ON: Using terminating resistance  
OFF: Not using terminating resistance

#### Multi-drop connection method with PC

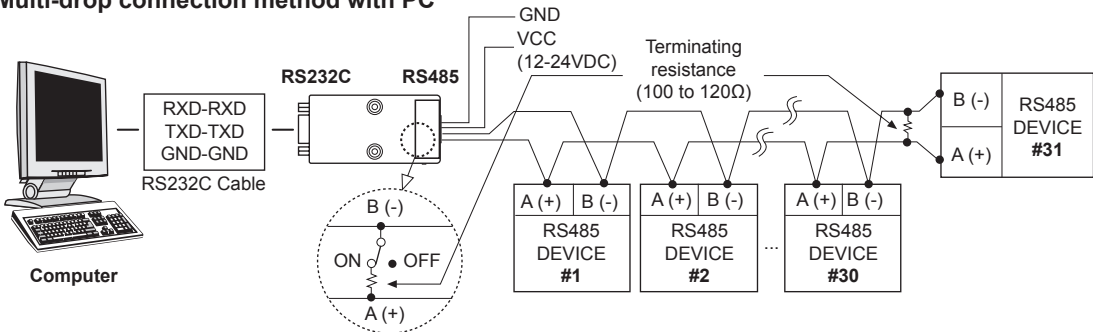

#### RS232C cable connection

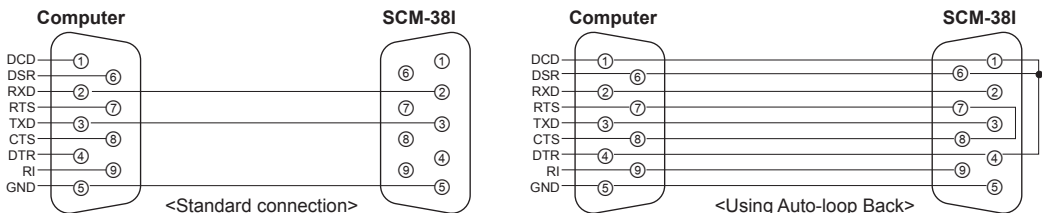

※When the software of the communication driver uses Auto-loop Back, please connect as the above.

### SCM-US

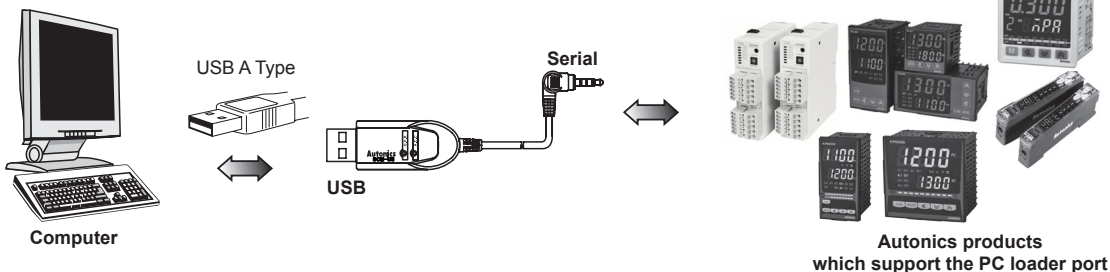

(A)	Photoelectric Sensors
(B)	Fiber Optic Sensors
(C)	Door/Area Sensors
(D)	Proximity Sensors
(E)	Pressure Sensors
(F)	Rotary Encoders
(G)	Connectors/Sockets
(H)	Temperature Controllers
(I)	SSRs / Power Controllers
(J)	Counters
(K)	Timers
(L)	Panel Meters
(M)	Tacho / Speed / Pulse Meters
(N)	Display Units
(O)	Sensor Controllers
(P)	Switching Mode Power Supplies
(Q)	Stepper Motors & Drivers & Controllers
(R)	Graphic/ Logic Panels
(S)	Field Network Devices
(T)	Software

# SCM Series

## ■ Driver Installation (SCM-US48I, SCM-US)

### ◎ USB Driver Installation

- 1) Visit our website ([www.autonics.com](http://www.autonics.com)) to download USB Driver.
- 2) Unzip the downloaded 'SCM-US48I.zip', or 'SCM-US.zip' at any directory.

- 3) When connecting product with USB port, 'Found New Hardware Wizard' will appear automatically. 'Do you want to search software by connecting 'Window Update'?. Click 'No' button and the following window will be displayed to proceed Driver installation. Select 'Install from a list or specific location' (Advanced) (S) and click 'Next'.

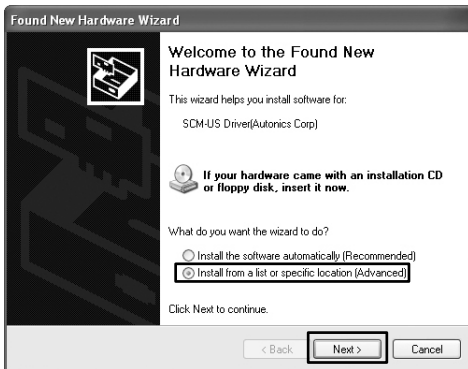

- 4) Select 'Search for best driver in these locations' and 'include this location in the search' continuously. Click the 'Browse' button.

- 5) When 'Browse Folder' window is displayed, select 'SCM-US\Driver' for SCM-US48I, SCM-US, and click 'Finish'. Click 'Next' to proceed with the USB Driver installation.

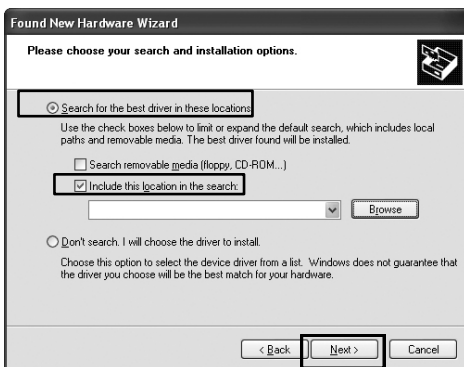

- 6) Hardware installation message will appear while Found New Hardware Wizard is running. Click 'Continue Anyway' to proceed with installation.



- 7) The following window will be displayed if the USB Driver is installed properly. Click the 'Finish' button.



## ◎ Serial Port Driver Installation

- 1) After installing USB Driver, Serial Port (COM port), 'Found New Hardware Wizard' will appear (Serial Port Driver installation follows the same procedures described in installing USB Driver).
- 2) After selecting 'Install from a list or specific location (advance)', click 'Next' button. The following window will be displayed for 'Search and installation options'
- 3) Because a driver location was selected when installing USB driver, click 'Next' button.

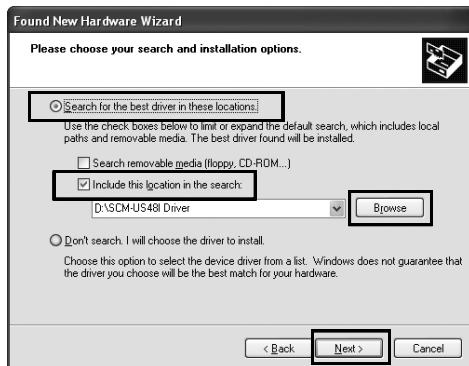

- 4) Hardware installation message will appear while Found New Hardware Wizard is running. Click 'Continue Anyway' to proceed with installation.
- 5) 'Completing the Found New Hardware wizard' will be displayed if the Serial Port Driver is installed properly. Click the 'Finish' button.



- ※Verify that drivers were installed properly with the windows Device Manager after finishing USB Driver and Serial Port Driver installation. Open the folder [My computer], open the system folder (click right), click the hardware tab, and click the Device Manager Button. Then, make sure that 'SCM-US48I Driver (Autonics Corp)' or 'SCM-US Driver (Autonics Corp)' is found in 'Common Serial Bus Controller' category and 'Port (COM and LPT)' is found in 'SCM-US48I Serial Port (COM □) or 'SCM-US Serial Port (COM □)'.

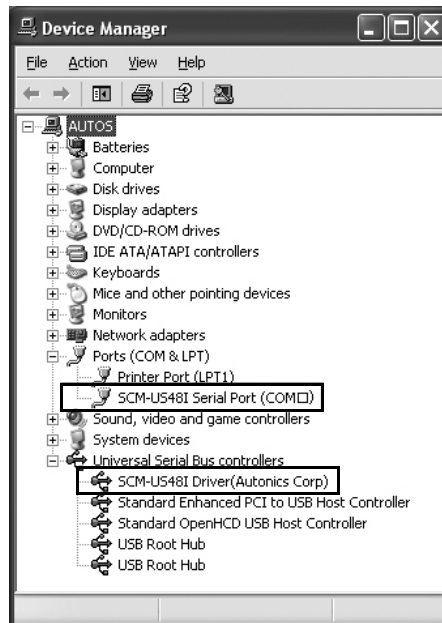

- ※This Driver Installation is described based on the procedure for Windows XP. There might be some differences in the specification above depending on OS.

(A)	Photoelectric Sensors
(B)	Fiber Optic Sensors
(C)	Door/Area Sensors
(D)	Proximity Sensors
(E)	Pressure Sensors
(F)	Rotary Encoders
(G)	Connectors/ Sockets
(H)	Temperature Controllers
(I)	SSRs / Power Controllers
(J)	Counters
(K)	Timers
(L)	Panel Meters
(M)	Tacho / Speed / Pulse Meters
(N)	Display Units
(O)	Sensor Controllers
(P)	Switching Mode Power Supplies
(Q)	Stepper Motors & Drivers & Controllers
(R)	Graphic/ Logic Panels
(S)	Field Network Devices
(T)	Software

## ■ Proper Usage

- In case of connecting PC with SCM-US48I or SCM-US, when changing PC USB port and connecting this unit to another (changed) USB port, USB driver will be reinstalled. This is not a malfunction.
- When connecting SCM-US or SCM-US48I communication module, please connect PC first. Then, connect RS485 communication product afterward. When disconnecting the units, remove the unit in reverse order.
- Using the Twisted pair cable (AWG24), which is suitable to RS485 communication is recommended. If the Twisted pair cable is not used, be sure preserving identically the length of A (+) and B (-) cables.
- After connecting SCM-38I, SCM-US48I with RS485 communication DEVICE, be sure to attach the terminating resistor (100 to 120Ω).
- In case of connect PC with SCM-US48I, or SCM-US, No. of COM Port will be numbered in order.  
This is not a malfunction. (e.g. COM 14, COM 15, ..., COM 256)
- When connecting SCM-US48I or SCM-US with USB cable, check COM port number before communication. It may take some time for computer to detect the cable after the cable is connected. (This is not a malfunction.)
- When connecting PC with SCM-US48I or SCM-US, do not use the extension cable to extend USB cable length. It may cause a malfunctions.
- Be cautious when using SCM-US as non-isolated type.
- Only use Autonics products that are available for SCM-US.
- Observe the rated voltage.
- To avoid malfunctions due to noise, do not place the unit close to a high-voltage power line.
- Proper application environment  
(Avoid following environments for unit to be used.)
  - Where severe vibration or shock exists
  - Where close to a strong alkali or strong acid
  - Where direct rays of light exist
  - Where near facilities generating strong magnetic forces or electric noise.
- Storage  
Keep the unit -20 to 60°C, 35 to 85%RH with avoiding direct rays of light. It is recommended to keep the unit package as it is.
- This unit may be used in the following environments.
  - Indoor
  - Altitude: Under 2,000m
  - Pollution degree 2
  - Installation category II